

MAXIO UIO

Distributed Universal (Analog) I/O Module



- ◆ 16 Universal (analog/sensor/contact) Inputs
- ◆ 6 20mA Analog Outputs
- ◆ Built-in sensor conditioning:
 - J, K, T, E, R, S, B, N Thermocouples
 - 100 & 1000 ohm RTDs (2-wire)
 - Type II & Type III 10K Thermistors
- ◆ 16-bit AI resolution, 12-bit AO resolution
- ◆ Dual protocol: Modbus RTU & Bricknet peer-to-peer
- ◆ Dual serial ports; RS-232/485 and internal radio or 2nd RS-232/RS-485 port
- ◆ Modular I/O Expansion to over 5,000 points over 5,000ft.
- ◆ Store & Forward repeating extends the reach of wireless systems
- ◆ 10 to 36Vdc or 10 to 26Vac power; use low-cost transformers
- ◆ Regulated 10 to 36V boosted, regulated, overload protected, analog sensor power
- ◆ Communications and CPU watchdog timers
- ◆ Programmable Power Management
- ◆ -40°C to +75°C Operating Temperature Range
- ◆ 3-year factory warranty

MAXIO UIO

Technical Reference Manual

Copyright Notice

This document is copyrighted, 2004, by Industrial Control Links, Inc.

All rights are reserved.

Industrial Control Links, Inc. reserves the right to make improvements to the products described in this manual at any time without notice.

No part of this manual may be reproduced, copied, translated or transmitted in any form or by any means without the prior written permission of Industrial Control Links, Inc. Information provided in this manual is intended to be accurate and reliable. However, Industrial Control Links, Inc. assumes no responsibility for its use, nor for any infringements upon the rights of third parties which may result from its use.

Acknowledgments

ScadaFlex, EtherLogic, EtherLogic LC, EtherLogic Ultima, MAXIO, ScadaWorks and **ScadaBuilder** are trademarks of Industrial Control Links, Inc.

ISaGRAF is a trademark of ICS Triplex, Inc.

In This Manual . . .

This manual provides the technical information required for system design and installation of MAXIO Universal Input/Output (UIO) modules.

If you have just purchased a MAXIO UIO module, we hope that you are as pleased using it as we have been developing it.

If you are reading this manual looking at a future purchase, we hope that you will consider a MAXIO I/O module when you have an application that needs rugged I/O expansion or distributed analog inputs and outputs.

Support

If you have questions or need help with an application, we hope that you'll take advantage of our free technical support. Simply call us at:

(800) 888-1893

If you need to send us a fax, use either:

(530) 888-1300 or **(530) 888-7017**

If you prefer e-mail (we do), please use the following address:

support@iclinks.com

For additional technical information including datasheets, manuals and software, visit our web site at:

www.iclinks.com

Contents

MAXIO UIO Overview

Introduction	6
---------------------------	----------

- Modular I/O Expansion
- Built-in Networking
- Wireless I/O
- Open Architecture
- Peer-to-peer Communications
- Local I/O Processing
- Wide Power Range and Power Management
- Rugged I/O
- Industry Leading Warranty

MAXIO UIO Familiarization	8
--	----------

Universal Inputs	10
-------------------------------	-----------

- Signal Types and Levels
- RAW Mode
- 5Vdc Mode
- 20mA Mode
- Resistance Type Sensors
- Resistance Mode
- Thermistor Modes
- RTD Mode
- Millivolt Mode
- Thermocouple Modes
- Contact Closure and Logic Level Discrete inputs
- Field Wiring
- Universal Inputs Terminal Block and Mode Switch Layout
- Internal Analog Inputs

Analog Outputs	21
-----------------------------	-----------

- Signal Types and Levels
- Output Scaling
- Field Wiring
- Analog Outputs Terminal Block Layout

Communications Interfaces	24
--	-----------

- RS-232 Serial Communications Interface
 - RS-485 Serial Communications Interface
 - Communications Connectors, LEDs and Address Switches
 - 2nd Serial Communications Interface
 - Network Addressing
 - Communications Configuration with the I/O Toolbox
-

Modbus Communications	27
Store & Forward	
Modbus Register Map	
Power	30
AC/DC Power Wiring	
Maintenance	31
ScadaFlex I/O Toolbox	
Firmware Updates	
Calibration	
Internal Spread Spectrum Radio Option	37
Radio Installation	
Radio Configuration	
MAIN MENU	
SET BAUD RATE	
SET OPERATION MODE	
EDIT RADIO TRANSMISSION CHARACTERISTICS	
SET OPERATION MODE	
SHOW RADIO STATISTICS	
EDIT MULTIPOINT PARAMETERS	
Specifications	45
Mounting Template	47

Introduction

MAXIO UIO modules are easy-to-use distributed input/output (I/O) devices that support, analog, sensor and contact closure devices for industrial and municipal monitoring and control. These modules can be interconnected with ScadaFlex or EtherLogic controllers for I/O expansion, connected to Programmable Logic Controllers (PLCs) or PC computers as rugged field I/O, or used with radios or leased-line modems to serve as low-cost Remote Terminal Units (RTUs).

MAXIO UIO modules provide 16 16-bit Universal Inputs and 6 12-bit 20mA Analog Outputs. Universal Inputs are enhanced analog inputs with support for not only traditional 5V and 20mA process signals, but include built-in conditioning and linearization for Thermocouple, RTD and Thermistor temperature sensors as well as contact closure type discrete input devices.

Modular I/O Expansion

MAXIO modules provide a very modular means of adding I/O capacity as needed, without the extra cost, wasted space and constraints of card racks. Need more I/O? Pop in a module. Want to add some inputs and outputs a few hundred yards away? String a single twisted pair of wires to a remote MAXIO module and you're up and running!

Built-in Networking

MAXIO UIO modules come network-ready with a dual-function, RS-232 and RS-485 serial communications interface. The RS-485 port can be used for low-cost 2-wire networking, with up to 254 modules distributed over 5,000 ft. The RS-232 port provides a simple point-to-point interface to radios and modems as well as PCs. An optional second RS-232/RS-485 interface may be ordered for the internal serial port, supporting redundant communications networks in high "uptime" systems.

Wireless I/O

MAXIO UIO modules may be ordered with a choice of internal 900MHz or 2.4GHz spread spectrum radios. Going wireless gives MAXIO modules a range of 10 to 20 miles, or even further using the built-in store & forward repeater feature. Adding an internal radio does NOT disable the RS-232/RS-485 interface, so a local PC or HMI panel can access the I/O module simultaneous with radio communications; ideal for system installation and testing!

Open Architecture

MAXIO modules support the Modbus RTU protocol, one of the most common

protocols used in control systems. This protocol is supported by thousands of other hardware and software products including all of the common PC-based MMI software packages from manufacturers such as Wonderware, Intellution, Iconics, and National Instruments.

Peer-to-peer Communications

For true peer-to-peer operation MAXIO modules support ICLs BrickNet protocol for use with ICL EtherLogic and Scadaflex Plus controller families. Protocol detection between Modbus and Bricknet is automatic.

Local I/O Processing

MAXIO modules perform local I/O processing. When used with thermocouples, the modules provide automatic cold junction compensation and linearization. Readings from RTDs and thermistors are also automatically linearized. All temperature sensor readings are presented in degrees C or F to a resolution of 0.1 degrees.

Wide Power Range and Power Management

MAXIO modules are designed for use in low-power solar and battery backed applications. They operate over a wide range of AC and DC power and have built-in power management features. A built-in sensor power supply provides a user settable regulated DC power output, from 7 to 36 Vdc, regardless of the input power (higher or lower). The sensor power output can be commanded OFF by the Host, making it possible to use popular 20mA sensors in low-power applications by only powering the sensor loops while taking sensor readings.

Rugged I/O

All Power, I/O and communications interfaces are protected against overloads, transients, surges, and reverse polarity. Self resetting polymer fuses are used extensively so that when the fault condition is corrected, the module automatically resumes normal operation.

Industry Leading Warranty

MAXIO modules are backed by an industry leading 3-year factory warranty.

MAXIO UIO Familiarization

The diagram below highlights the main physical features of the MAXIO UIO Module that are discussed in the remainder of this manual.

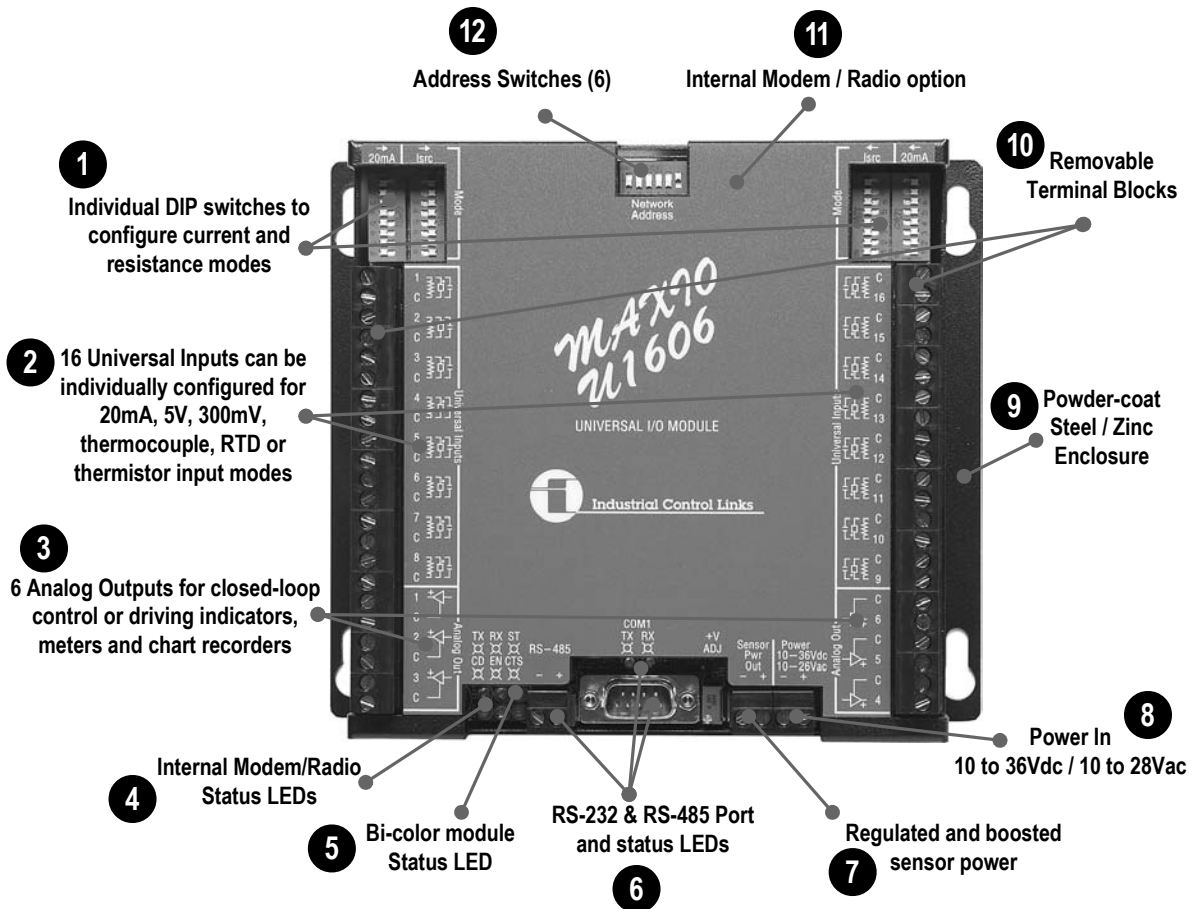

1 Current/Resistance Mode Configuration Switches

Set these switches for individual inputs used for 20mA sensors (outer switch banks) or resistance sensors (inner switch banks) such as thermistors and RTDs, as well as contact closure discrete inputs.

2 16 Universal Inputs

Universal Inputs are enhanced analog inputs with support for not only traditional 5V and 20mA process signals, but thermocouple, RTD and thermistor temperature sensors as well as contact closure type discrete input devices. Each of the 16 inputs can be configured for any sensor type.

3 6 Analog Outputs

MAXIO UIO modules come with 6 analog outputs to compliment the Universal Inputs for use in closed-loop (PID) control systems, as well as operating, positioners, dampers, analog displays and meters, and driving chart recorders.

4 Internal Radio/2nd Serial Port Communications Status LEDs

Transmit and Receive Data LED indicators show network communications activity to confirm operation and assist in system troubleshooting.

5 Bi-color Status LED

A bi-color status LED shows that the module is powered and operating normally (green) or has shut down the outputs because of a communications link failure (red). The LED flashes red when the sensor power supply is overloaded (over-current/short circuit protection).

6 RS232 and RS-485 Main Communications Port

MAXIO I/O modules have a dual interface primary communications port; RS-232 for short connections to PCs and external modems/radios, and RS-485 for low-cost 2-wire networking up to nearly a mile.

7 Regulated and Boosted Sensor Power Supply

Regardless of the input power, MAXIO UIO modules provide regulated power for sensors. The Host systems can switch this power ON and OFF remotely to manage power consumption.

8 Wide Range AC/DC Power

MAXIO I/O Modules accept AC power (10 to 26V) or DC power (10 to 36V). The internal power is regulated and transient protected, so low-cost power supplies or transformers can be used reliably.

9 Tough Powder-coated Zinc-plated Steel Enclosure

Extremely long lasting dual coating for harsh environments

10 Hot-swappable Removable Terminal Blocks

The I/O, Power and Communication terminal blocks and connectors can be safely removed and reinserted easily, without taking your system down.

11 Internal Radio or 2nd Serial Port

MAXIO I/O modules have an extra serial port for an optional radio or extra RS-232/RS-485 interface. The internal port is truly independent and can be used simultaneously with the main RS-232/RS-485 port. The second serial port simplifies local support of distributed I/O systems as well as systems that require redundant I/O network communications.

12 Network Address Switches

DIP switches are used for field addressing MAXIO I/O modules. Up to 64 modules can be addressed with the switches, expandable to 255 modules via the I/O module "toolbox" configuration software.

Universal Inputs

The MAXIO UIO Module has sixteen Universal Inputs. The Universal Inputs accept both analog input and discrete input signals including signals from sensors that monitor levels, flows, temperatures, pressure, etc. as well as discrete input devices such as switches and relays contacts. Built-in signal conditioning eliminates the need for most external signal converters.

Analog measurements are made with a 20-bit Delta-Sigma Analog-to-Digital (A/D) converter preceded by a transient protected front-end. The Universal Inputs are isolated from the main logic power and have their own internal DC-DC converter; no external power supply is required.

Signal Types and Levels

The MAXIO universal inputs may be individually configured to accept standard 20mA or 5V process control signals, thermocouples, low-level millivolt sensors, resistive sensors such as thermistors, RTDs and potentiometers, and contact closures. With a pair of external resistors, the inputs can be configured for higher voltages of either polarity (i.e +/-10Vdc). The input mode and sensor type are determined by (Modbus) register settings. The module can be configured by commands from any Modbus (or Bricknet) Master, or using the ICL ScadaFlex I/O Toolbox software pictured below.

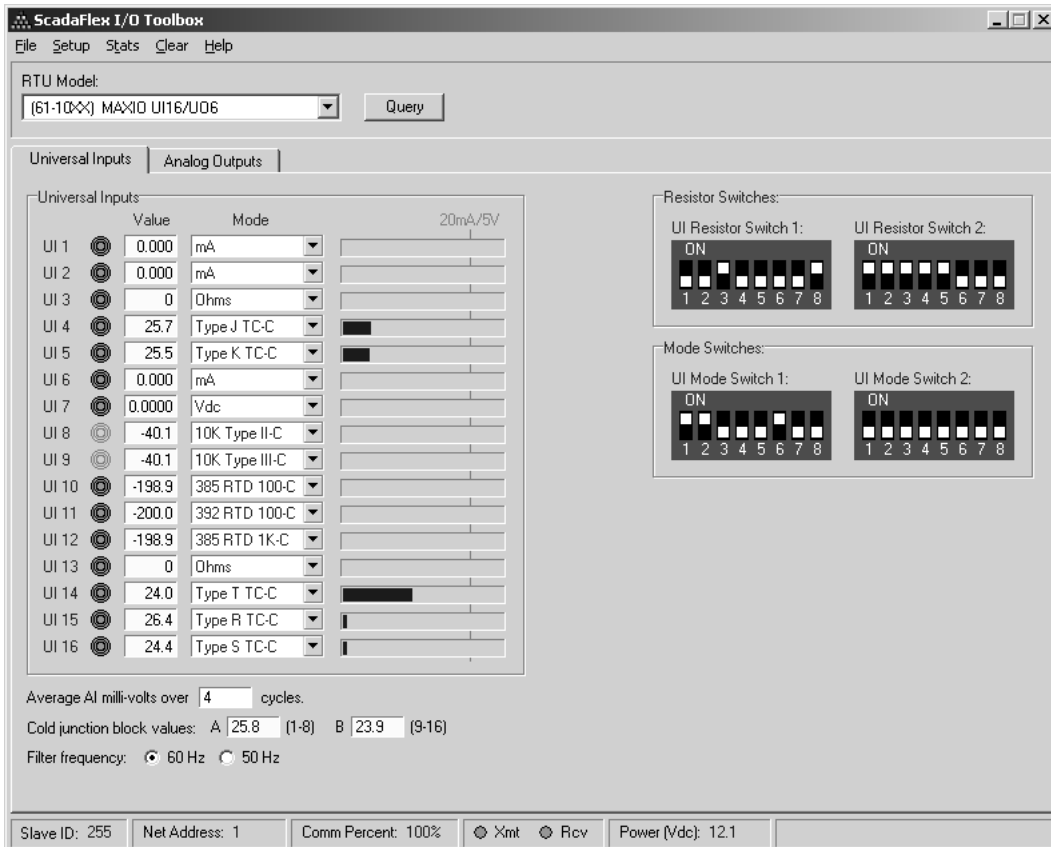

The configuration of MAXIO UIO modules can be read or changed at any time with simple register commands. The module configuration is retained in non-volatile EEROM memory so that the settings are “remembered” even after the module is powered off. No batteries are used.

For current loop and resistive sensors, the user must also set switches next to the Universal Input terminal blocks that enable or disable precision current sense resistors required for handling 20mA sensors, or current sources for resistive measurements.

RAW Mode

Raw mode bypasses all scaling and calibration in the UIO module, providing “raw” 16-bit readings from the A/D converter. A full scale reading of 65535 represents an input of approximately 5Vdc. If the current configuration switches are enabled, the input current can be calculated as the voltage drop read across a precision 121ohm resistor, or just over 40mA for a full scale readings of 65,535. The calculation is:

$$\text{A/D Reading} = (65535 * \text{mA} * 121) / 5$$

If the current sources are enabled (for resistance measurements), the RAW readings are the ratiometric values read across the input resistance in series (bottom portion of a voltage divider) with a precision 20,000 ohm 0.1% low-drift resistor connected to the A/D reference. The calculation is:

$$\text{A/D Reading} = 65535 * R / (R + 20,000)$$

where R is the input resistance being measured. For example, a 10,000 resistor will read approximately 21845 counts:

$$65535 * 10,000 / (10,000 + 20,000) = 21845$$

5Vdc Mode

When configured for voltage measurements, the MAXIO UIO module measures signals from 0 to 5.6 volts (5 volts plus 12% over-range) with a resolution of just over 16-bits. There’s no loss of accuracy in this over-range area, so it’s possible to accurately read the signal levels from slightly misadjusted sensors that run “a little hot”. It’s also possible to distinguish between a sensor output that is at full scale versus over-range.

The UIO module scales and performs calibration correction on the readings, so that a full scale reading of 5.6Vdc is presented to the Host system as a value of 56000 (10,000 counts per volt). This provides readings that without further scaling, read out directly in 100uV increments (imagine a decimal point 4 places from the right to interpret the readings in volts).

20mA Mode

When configured for milliampere measurements, the MAXIO UIO module measures signals from 0 to just over 40mA (200% over-range for “standard” 20mA signals). The UIO module scales and performs calibration correction on the readings, so that a full scale reading of 40mA is presented to the main CPU as a value of 40000 (1,000 counts per milliampere). The milliampere mode is typically used to measure the output of 4 to 20mA sensors. The readings from these sensors will come back to the Host system as 4000 for 4mA and 20,000 for 20mA.

Current is measured by reading the voltage drop across a 121 ohm precision resistor through which the current is flowing. Besides setting the input mode in the UIO module, current loops require that the current sense resistors be enabled by setting a DIP switch (labeled 20mA) next to their respective input connector. There is a separate switch for each input.

Resistance Type Sensors

Resistance measurements and resistive type sensors such as thermistors, RTDs and pots require a current source. A second set of switches next to the current loop switches (labeled “Isrc”) enables the current source for individual inputs. **Be sure that the current loop switch and the current source switch for a channel are not turned ON at the same time.**

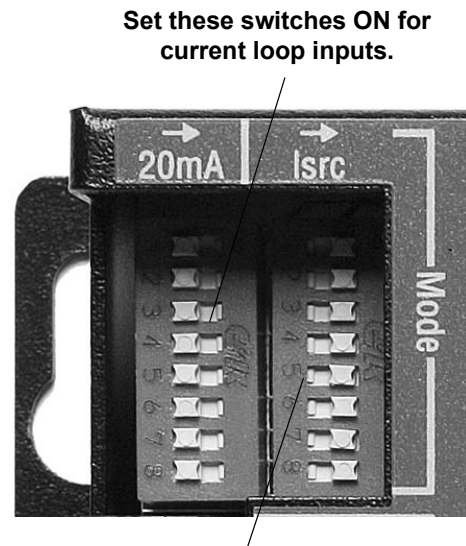

Set these switches ON for resistance, thermistors, RTDs and contact closures.

Resistance Mode

MAXIO UIO modules can measure resistance from 0 to 65,535 ohms. The resolution is 1 ohm below 20,000 ohms and several ohms towards the top of the range. The resistance mode is typically used to read the resistance of potentiometer sensors that indicate position or rotation.

Resistance is measured by sourcing current through a precision 20,000 ohm reference resistor that is in series with the sensor. The microprocessor in the UIO module measures the voltage drop at the junction of the reference resistor and the sensor and compares it to the reference voltage. The microprocessor is then able to ratiometrically calculate the sensor resistance.

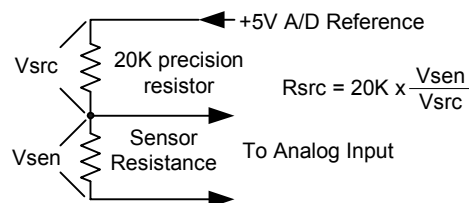

Thermistor Modes

Thermistors are temperature sensors that are popular for use in HVAC, building monitoring and automotive applications. The resistance of a thermistor varies non-linearly with temperature, so the UIO module automatically corrects for the non-linearity and provides a calibrated reading in degrees C or F back to the host system.

The MAXIO UIO module supports two common types of thermistors; 10K ohm, Type II and III (resistance is 10,000 ohms at 25°C/77°F). The only difference between them is the “shape” of their temperature to resistance curves. The supported temperature ranges and corresponding readings from the UIO module are:

Sensor Mode	Temperature	From UIO Module
Type II - Deg C	-40.1°C to 203.4°C	-401 to 2034
Type II - Deg F	-40.1°F to 398.1°F	-400 to 3981
Type III - Deg C	-40.1°C to 201.1°C	-401 to 2011
Type III - Deg F	-40.1°F to 393.9°F	-400 to 3939

The table below shows the temperature to resistance relationship for the 10,000 ohm thermistors supported by the MAXIO UIO module.

Deg C	Deg F	10K Type II - ohms	10K Type III - ohms
-40	-40	335,671	239,831
-35	-31	242,195	179,280
-30	-22	176,683	135,233
-25	-13	130,243	102,890
-20	-4	96,974	78,930
-15	5	72,895	61,030
-10	14	55,298	47,549
-5	23	42,314	37,316
0	32	32,650	29,490
5	41	25,395	23,462
10	50	19,903	18,787
15	59	15,714	15,136
20	68	12,493	12,268
25	77	10,000	10,000
30	86	8,056	8,197
35	95	6,530	6,754
40	104	5,324	5,594
45	113	4,366	4,656
50	122	3,601	3,893
55	131	2,985	3,271
60	140	2,487	2,760
65	149	2,082	2,339
70	158	1,751	1,990
75	167	1,480	1,700
80	176	1,256	1,458
85	185	1,070	1,255
90	194	916	1,084
150	302	185	238

RTD Mode

RTDs are another form of resistance temperature sensor. They are frequently used in HVAC and refrigeration applications. Although the relationship between resistance of an RTD and temperature is considerably more linear than thermistors, the microprocessor in the UIO module must still linearize the readings to provide accurate values back to a Host system.

The MAXIO UIO module supports both 100 and 1000 ohm platinum 2-wire RTDs (TCR = 0.00385). Although 100 ohm RTDs are supported, their accuracy will be less than 1000 ohm RTDs because a 2-wire measurement technique is used, so lead length introduces errors. For every degree C of change in temperature, the resistance of 1000 ohm RTDs changes by about 3.85 ohms, whereas 100 ohm RTDs change by 0.385 ohms per degree. In critical applications, try to keep lead lengths very short or avoid using 100 ohm RTDs. The temperature ranges supported for RTDs are:

Sensor Mode	Temperature	From UIO module
100/1000 ohm RTD - Deg C	-198.9°C to 869.4°C	-1989 to 8694
100/1000 ohm RTD - Deg F	-326.0°F to 1596.9°F	-3260 to 15969

The relationship between temperature and RTD resistance is:

Deg C	Deg F	100 RTD - ohms	1K RTD - ohms (TCR = 0.00385)
-40	-40	84.7	847
-30	-22	88.5	885
-20	-4	92.2	922
-10	14	96.1	961
0	32	100.0	1000
10	50	103.9	1039
20	68	107.8	1078
30	86	111.7	1117
40	104	115.5	1155
50	122	119.4	1194
60	140	123.2	1232
70	158	127.1	1271
80	176	130.9	1309
90	194	134.7	1347
100	212	138.5	1385
110	230	142.3	1423
120	248	146.1	1461
130	266	149.8	1498
140	284	153.6	1536
150	302	157.3	1573
160	320	161.0	1610
170	338	164.8	1648
180	356	168.5	1685
190	374	172.1	1721
200	392	175.8	1758
210	410	177.4	1774
220	428	180.9	1809
230	446	184.5	1845
240	464	188.0	1880
250	482	191.5	1915

Millivolt Mode

The MAXIO UIO module can accurately measure very small signal levels like those from “bridge” type pressure transducers and low power devices such a solar radiation sensors. In the millivolt mode, the UIO module has a full scale measurement range of +/-300mV. The microprocessor in the UIO module scales and performs calibration correction on the low-level readings, so that a full-scale reading of +/- 300mV is presented back to the Host system as a value of +/-30,000 (10,000 counts per 100mV). Besides reading the output of low-level sensors, this mode is useful for creating custom input voltage ranges using an external resistor voltage divider.

Typical custom ranges and their corresponding divider values are listed below. The resistor values shown provide approximately a 150% over-range capacity (+/-200mV signal for the listed full-scale values) The values were also chosen to provide a 10K ohm or greater load on the signal source.

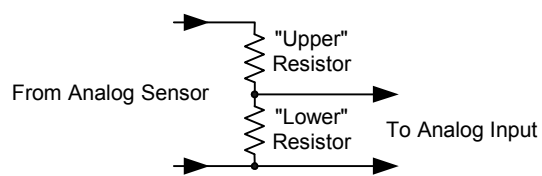

Range	“Upper” resistor	“Lower” resistor
+/-1Vdc	8.06K ohm 1%	2.0K ohm 1%
+/-5Vdc	12.1K ohm 1%	499 ohm 1%
+/-10Vdc	24.3K ohm 1%	499 ohm 1%

Noise rejection configuration

Low-level millivolt and thermocouple signals can be susceptible to noise. Configuration registers in the MAXIO UIO module can be set to configure the MAXIO microprocessor to average multiple readings (calculated rolling average) and to select 50/60Hz (power-line) noise rejection to reduce the effects of noise. The trade off is that the greater the noise rejection, the slower the response time to signal level changes. The configuration registers are also accessible through the ScadaFlex I/O toolbox software (lower portion of the Analog Input Section) as shown below:

Signal Averaging

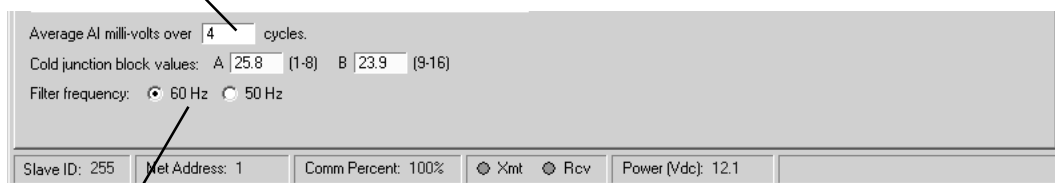

AC Line Filtering

Thermocouple Modes

The MAXIO UIO module supports temperature measurements using thermocouple sensors. No external signal conditioners are needed for any combination of type J, K, T, E, R and S thermocouples.

! *Only use ungrounded type thermocouples (electrically isolated junction).*

Thermocouple signals require linearization and cold-junction compensation. In the MAXIO UIO module, the cold junction (terminal block) temperature is measured by a pair of solid-state temperature sensors, one located in close proximity to each I/O terminal block. The current temperature readings from these sensors are available in a pair of Modbus registers that can also be viewed near the bottom of the Analog Inputs window in the Scadaflex I/O toolbox software as shown below.

Cold junction temperatures



The microprocessor in the UIO module automatically performs the required compensation and linearization calculations so that an accurate scaled and calibrated temperature reading in degrees C or degrees F is provided back to the Host system. The inputs have upscale burnout protection, forcing a maximum temperature reading for an open thermocouple sensor. The supported temperature ranges and corresponding readings for each of the thermocouple types are listed below:

Thermocouple	Temperature Range	From UIO Module
Type J - Deg C	-240.7°C to 1199.0°C	-2407 to 11990
Type J - Deg F	-401.2°F to 2190.2°F	-4012 to 21902
Type K - Deg C	-261.2°C to 1369.5°C	-2612 to 13695
Type K - Deg F	-438.1°F to 2497.1°F	-4381 to 24971
Type T - Deg C	-263.2°C to 398.8°C	-2632 to 3988
Type T - Deg F	-441.7°F to 749.8°F	-4417 to 7498
Type E - Deg C	-267.4°C to 999.0°C	-2674 to 9990
Type E - Deg F	-449.3°F to 1830.2°F	-4493 to 18302
Type R - Deg C	-43.1°C to 1759.8°C	-431 to 17598
Type R - Deg F	-45.5°F to 3199.6°F	-455 to 31996
Type S - Deg C	-41.3°C to 1759.1°C	-413 to 17591
Type S - Deg F	-42.3°F to 3198.3°F	-423 to 31983

Contact Closure and Logic Level Discrete Inputs

In addition to analog type sensors, the Universal Inputs of the MAXIO UIO module can accept simple discrete input signals in the form of contact closures and low-level logic signals. Unlike the discrete inputs in other I/O modules, the universal inputs can use the built-in current sources available for resistance measurements so that no external “wetting” current is required for contact closure type sensors (switches, relay contacts, etc.). The inputs are also more sensitive so they are capable of accepting TTL and CMOS logic levels which typically run between 3 and 5Vdc.

Do NOT apply any voltage in excess of 5.5Vdc to a Universal Input, otherwise the overload protection circuitry will take over and clamp the input at approximately 6Vdc.

The microprocessor in the UIO module actually processes a discrete sensor on a Universal Input like any other analog sensor, so the inputs are heavily filtered and respond much more slowly than the conventional discrete inputs. Do not use these inputs if you require response times faster than 1 second!

The Universal Input signals are read from the MAXIO UIO module as DI1 through DI16. No mode configuration is required to use a Universal Input as a discrete input. If the voltage level on an input is HIGH (a voltage of 2.50Vdc or greater), it is considered OFF. A LOW (any voltage level below 2.50Vdc) is considered to be ON. If a contact closure type sensor is to be used, the “Isrc” switch for that channel should be turned ON, pulling the input HIGH until the switch closes to ground. If a low-level logic signal is used, leave the current source resistor OFF.

Field Wiring

The universal input connections come into the UIO module on a pair of 16 position removable terminal blocks. There are 8 sensor input connections and 8 common connections, one per input channel, on each terminal block. The common connections on each terminal block are electrically tied together, but isolated from the other Universal Inputs, the Analog Outputs, and the rest of the UIO circuitry such as the communications interfaces.

For 20mA or 5 volt sensors, the universal inputs are passive, requiring an active signal source. 20mA current loop devices must either have their own internal loop power supplies, or an external supply must be used (such as the Sensor Power Output built into the UIO module as shown below). Voltage type sensors are typically self-powered anyway. It is best if self-powered devices are isolated to avoid ground loops.

Thermocouples **MUST** be non-grounded type (electrically isolated).

Thermistors, RTDs and other resistive sensors are isolated by design, so no special precautions are required.

Typical wiring to the first eight universal inputs (left-hand terminal block) is shown here. The second group of eight inputs are mirrored on the right-hand side of the module and follow the same wiring configuration.

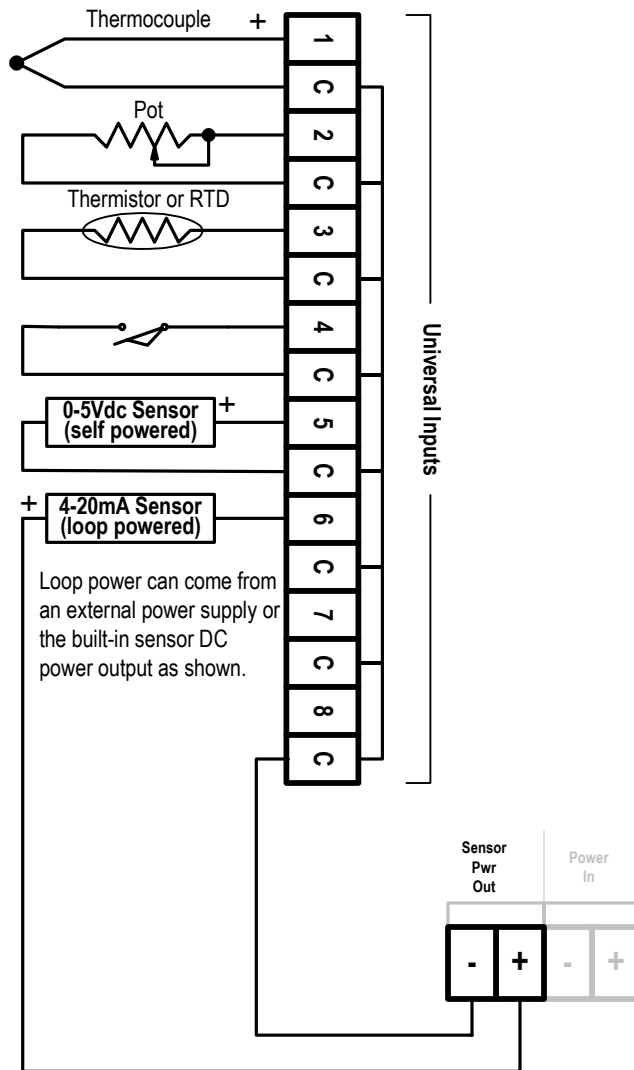

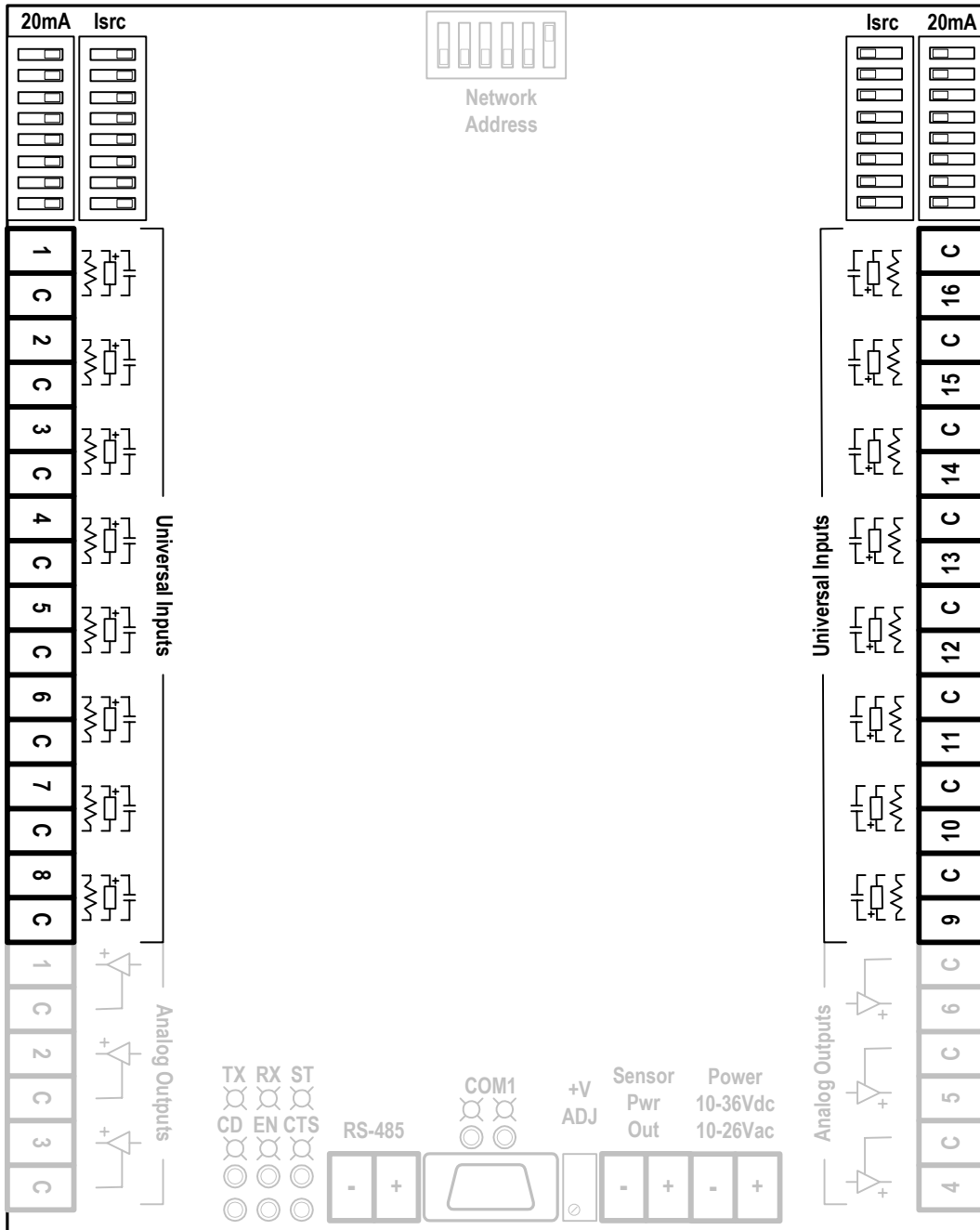

MAXIO Universal Inputs - Terminal Block and mode Switch Layout

Internal Analog Inputs

MAXIO UIO modules have 4 internal analog inputs used to monitor operating voltages and temperatures. Each of these can be read as an integer register value by the Host system. All voltages are in tenths of a volt (i.e. 254 = 25.4 volts). Temperature is in tenths of a degree C (i.e. 282 = 28.2°C)

Input Voltage

This register represents the current external DC or rectified AC input voltage (power) to the UIO module.

Sensor Power

This register represents the current output voltage of the regulated sensor power supply. There is a separate ON/OFF control bit for this power source, so if the program shuts this supply off, this register will read 0. The sensor power supply is overload protected. If an external source begins to draw more than 600mA, the power supply output is automatically reduced. Besides triggering a Sensor Power Overload warning bit (see DI Modbus Registers), the sensor power level will be seen to drop in this register. The sensor power is user settable from approximately 7Vdc and 32Vdc.

Cold Junction Temperature (x 2)

These registers represent the temperature of the Universal Input terminal blocks on either side of the module. Although these are primarily used for cold junction compensation of thermocouple sensor readings, the temperature readings generally represent the internal temperature of the UIO module. These sensors are purposely located away from heat generating components, so there may be certain locations in the module that run somewhat warmer than the indicated temperature. Use these values as an average internal temperature indication. The maximum recommended operating temperature of the MAXIO UIO module is 75°C.

Analog Outputs

Analog outputs are used to control variable speed motors (drives), valves and positioners. The MAXIO UIO module has 6 12-bit analog outputs.

Signal Types and Levels

The analog outputs produce 0 to 20mA control signals. The common 4 mA offset required by 4 to 20mA control devices is accomplished by software in the Host system.

With the addition of a single external resistor (per channel), the outputs can be converted to voltage outputs (i.e 0 to 5Vdc or 0 to 10Vdc).

The resistor value can be calculated as: **$R_{sense} = V_{out} / 0.02$**

The resistor values required for common voltage ranges are:

Output Range	Sense Resistor Values
0 to 1Vdc	50 ohms (1/8 watt or more)
0 to 5Vdc	250 ohms (1/8 watt or more)
0 to 10Vdc	500 ohms (1/4W or more)

Common 1% values of 49, 249 and 499 ohms may be substituted for the “ideal” values listed above.

The UIO module analog outputs source current from the modules input power, or the sensor (boost) power supply, whichever one has the highest output voltage. The commons of the analogs outputs are connected to the modules power supply common, so control devices connected to these outputs should be isolated to avoid unforeseen ground loops.

Output Scaling

The MAXIO UIO Analog Outputs are scaled to provide a 0 to 20mA output signal with output values of 0 to 20,000 (1 count = 1uA). The outputs have an additional 5% or so of headroom, so it's possible to use values greater than 20,000 to get output levels slightly higher than 20mA. Note that since the outputs have an actual resolution of 12-bits (a range of 0 to 20,000 would require in excess of 14 bits), it will require an increase or decrease of several counts in the analog output value to cause a change in the actual current output. The 0 to 20,000 scaling is simply done for the convenience of system setup.

Field Wiring

The Analog Outputs from the UIO module are connected to field devices via 6-positions (3 signals and 3 commons) on each of the removable I/O terminal blocks.

Typical wiring to the Analog Outputs is shown in the diagram on the right. Note that no external loop power supply is required.

If a low input voltage is used to power the module (12 volts for example), or if multiple output devices are placed into the loops, then the Sensor Power Supply will be required to power the output loops (the analog output loops are powered by either the module input power or the Sensor Power Supply, whichever has the higher voltage level).

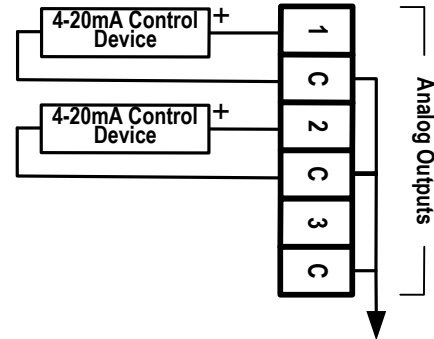

**Analog Outputs
Field Wiring Example**

Setting the level of the Sensor Power Supply is a trade-off between power consumption and loop compliance depending on the number of devices in the loops. Remember that the Sensor Power Supply may also be required to power the Analog Input loops. Set the Sensor Supply so that there is sufficient compliance for all of the devices in the loops (control devices, indicators, chart recorders, etc.) PLUS approximately 5 volts for the internal Analog Output circuitry in the controller. Since most process devices require 5 volts or less of loop voltage (250 ohms), the loop can be powered by as little as 12 volts for a single device, 15 volts for two devices and 20 volts for 3 devices while still leaving a little bit of headroom. Minimizing the loop voltage reduces power consumption, so in power sensitive applications, try to minimize the loop voltage level while allowing for enough loop compliance.

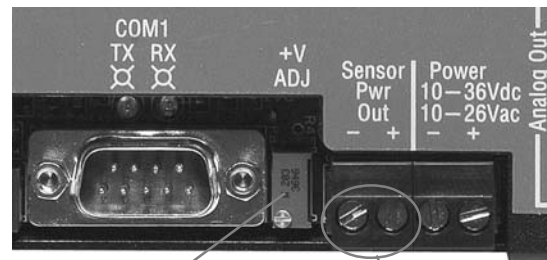

Sensor Power Supply
voltage adjustment

Sensor Power Supply output

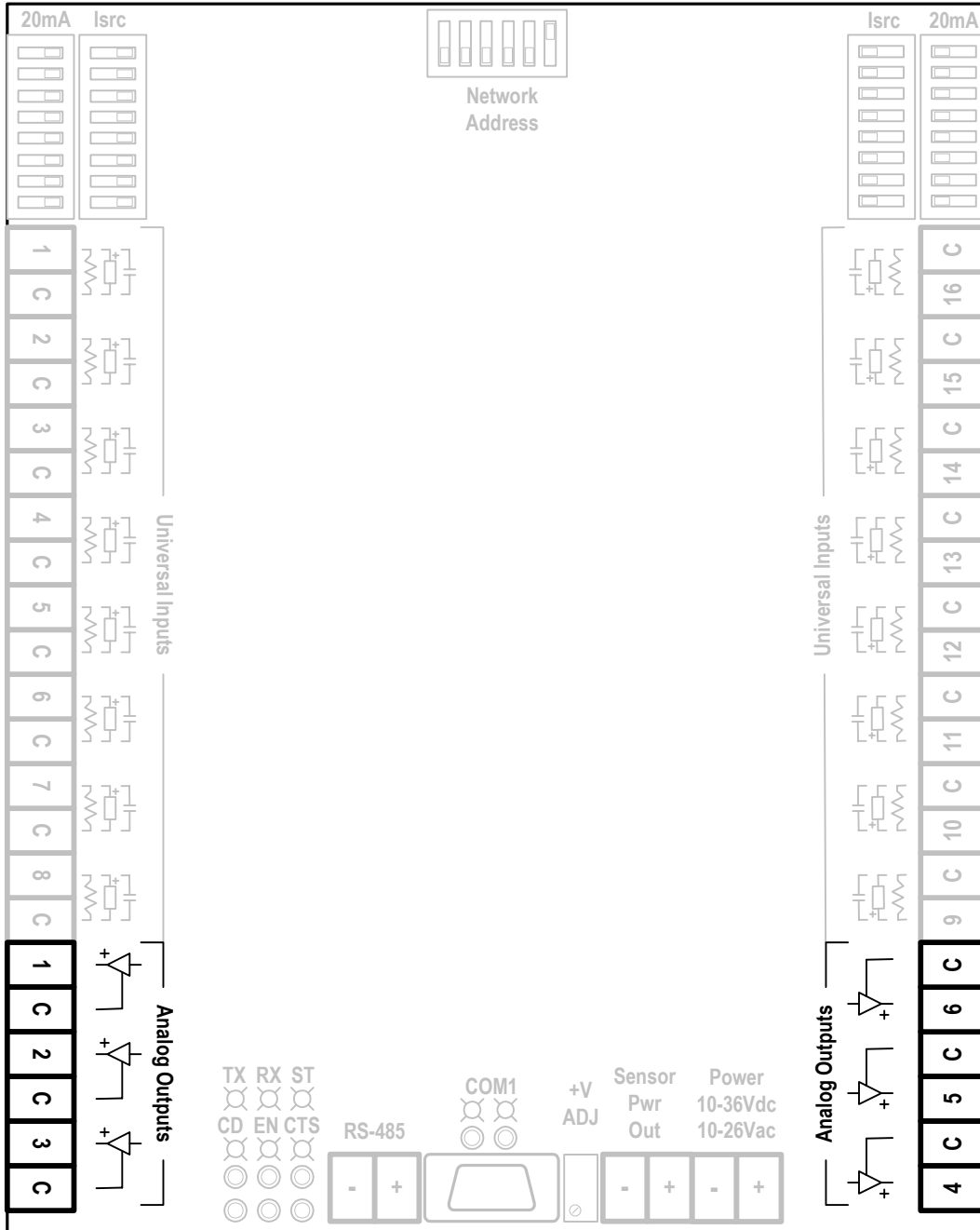

MAXIO Analog Outputs - Terminal Block Layout

Communications Interfaces

The most common serial communications standards for SCADA and industrial control systems are RS-232 for short point-to-point connections and RS-485 for longer distance networked communications. MAXIO I/O Modules have a dual-interface primary serial port with both RS-232 and RS-485 interfaces. Only one interface (RS-232 or RS-485) may be used at a time.

RS-232 Serial Communications Interface

On a MAXIO I/O Module, the RS-232 serial interface is a simple 3-wire configuration. It does not require, or support, any modem control lines. The RS-232 port connections are available on a male 9-pin “D” connector with transmit, receive and ground pin assignments identical to a PC computer. To connect a MAXIO I/O module to a PC computer, a “null modem” cable is required to “cross over” the transmit and receive data lines.

RS-485 Serial Communications Interface

RS-485 is a 2-wire communications interface designed for networked operation spanning distances of up to 5,000 ft. MAXIO I/O modules are frequently used with EtherLogic and ScadaFlex Plus Controllers for I/O expansion. These controllers have one or more RS-485 ports. RS-485 is popular because of its two-wire simplicity, superior noise rejection and operating distance.

Up to 254 MAXIO I/O modules may be connected on a single RS-485 network, distributed over several thousand feet. Although the original RS-485 standard allowed for only 32 devices on a network, the RS-485 interface in MAXIO I/O modules (as well as ScadaFlex Plus and EtherLogic Controllers) is specially designed to allow up to 254 devices to share the same network. With up to 40 I/O points per module, a network of 254 MAXIO UIO modules provides over 5,000 I/O points!

A two-pin removable terminal block is used for the RS-485 connections on a MAXIO I/O module. A typical RS-485 network uses a twisted pair cable. If the cable is shielded (recommended for most installations), the shield should be connected to earth ground at **ONLY ONE END** of the cable.

Connect the wiring exactly as shown (+ to + to +, - to - to -). Unlike traditional RS-485 networks, external termination resistors **SHOULD NOT** be used since termination is already built into the I/O modules and controller.

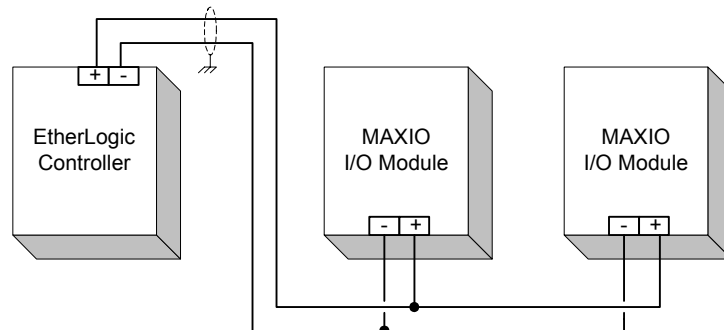

2nd Serial Communications Interface

In addition to the primary RS-232/RS-485 interface, MAXIO I/O Modules have a second serial channel to support an internal spread spectrum radio for wireless communications, or a second RS-232/RS-485 port to support an external radio or redundant hardwired network communications. The 2nd serial port operates independently of the primary port.

Network Addressing

The network address of a MAXIO I/O module is set by a 6-position DIP switch at the top of the module. These 6 switches can be set to 64 different address combinations (note that 0 is NOT a valid address). Every module MUST have a unique address on the network. MAXIO I/O modules may be configured to addresses above 63 by setting a “base value” with the ScadaFlex I/O toolbox software. The base address value is added to the value set in the switches, effectively shifting the range of the address switches “up” by the base address value. For example, if the base address is set to 100, then the DIP switch will address the module to network addresses from 100 to 163. For diagnostic purposes, MAXIO I/O modules always respond to address 255 in addition to the user selected address.

Communications Configuration with the I/O Toolbox

The ScadaFlex I/O Toolbox is used to configure and exercise MAXIO I/O modules when they are connected to a PC computer. The settings that configure the basic communications parameters are accessed via the RTU Configuration window shown here.

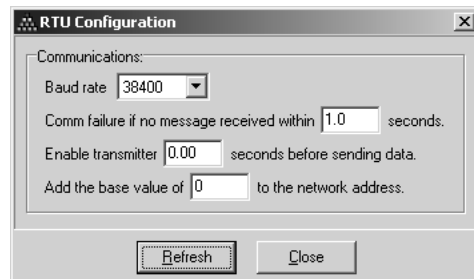

Baud Rate: This parameter sets the communications character rate, from 2400 to 115,200 baud.

Comm Fail Time: This parameter sets the timeout value for a communications failure. The MAXIO I/O module will sense a communications failure if a valid message is not received from a Host within the specified time period. The timeout time can be set from 0 (disabled) to 6553.5 seconds (109 minutes). When a communications failure is detected, the modules main Status LED (“ST”) turns RED and all analog outputs are forced to 0mA.

Transmit Enable Lead Delay: This parameter sets the time from when the RS-485 transmitter is enabled to when the first byte of data is sent, forcing a “quiet” period after the transmitter turns ON. Set this value to 0 for most RS-485 networks, as well as for RS-232 operation.

Network Base Address: This parameter sets the base address added to the value in the DIP switches to determine the modules network address.

Network Address Switches

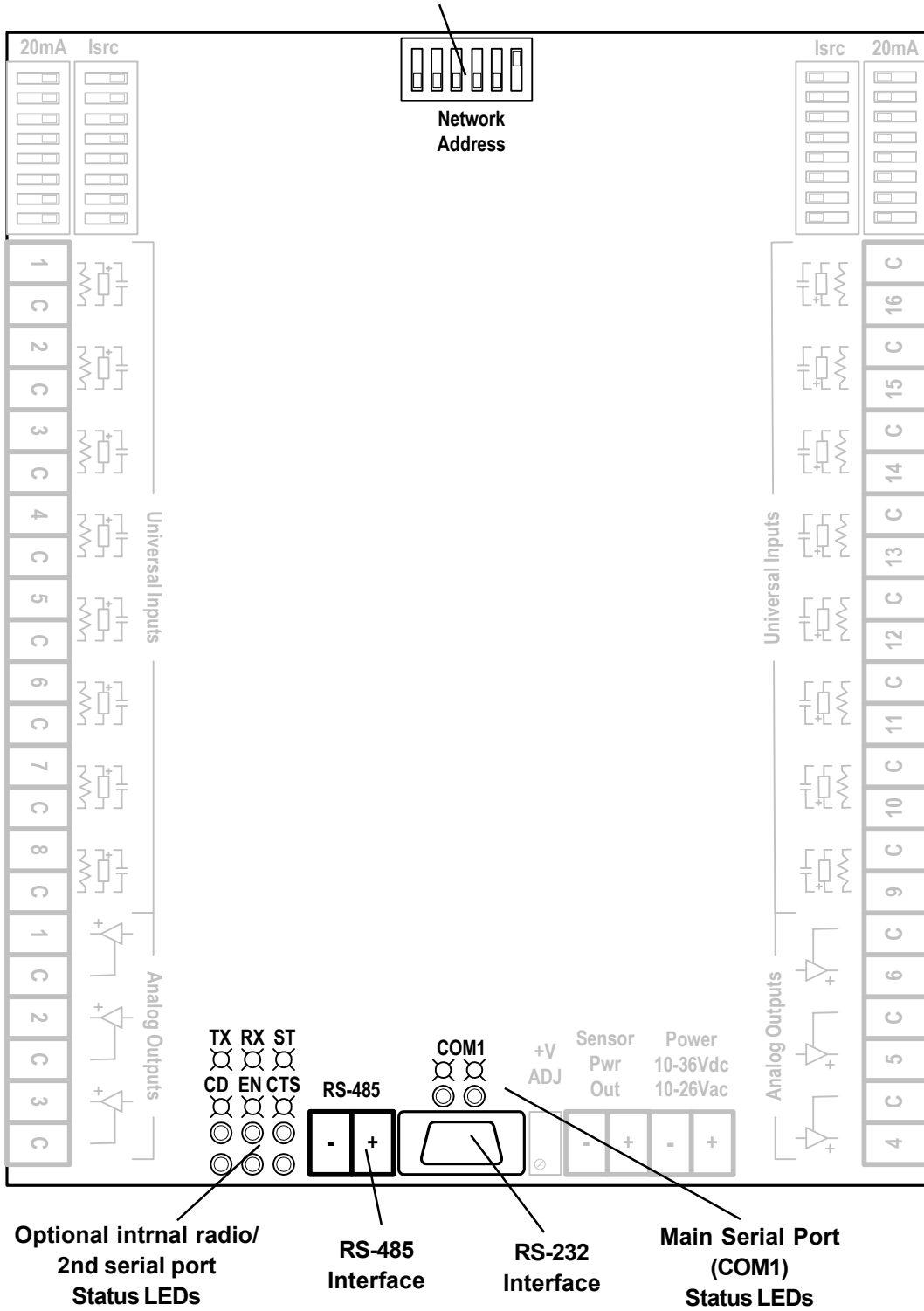

MAXIO I/O Module - Communications Connectors, LEDs and Address Switches

Modbus Communications

MAXIO I/O modules support the Modbus RTU communications protocol. This protocol was originally developed for Modicon Programmable Logic Controllers (PLCs). Now, Modbus is supported by nearly every PLC and RTU, and most HMI/MMI software packages. MAXIO I/O modules can be used in a large number of existing systems and will work without special drivers with many different “Hosts”.

MAXIO I/O modules support the following four standard Modbus data types:

Data Type	Modbus Type	Description
Status	10xxx	Read Only bits
Coils	00xxx	Read/Write bits
Input Registers	30xxx	Read Only 16-bit values
Holding Registers	40xxx	Read/Write 16-bit values (two combined for 32-bit values)

Note: Do not confuse the Modbus Type with the command codes used to access the various data types.

Both the single and multiple element forms of the Modbus commands that access these data types are supported. For example, there is a command to read or write a single Holding Register, and another command to access a block of Holding Registers. MAXIO I/O modules support both forms.

MAXIO I/O modules allow up to 128 registers of any type to be accessed in a single message. Be careful to only access valid registers. In general, messages that access unassigned registers are rejected as invalid messages, unless they are reserved for future use.

Detailed information on the Modbus protocol is available at: www.modbus.org

Store & Forward

MAXIO I/O modules can be used in radio based systems. To extend the effective range of radio systems, MAXIO I/O modules may be configured to digitally repeat messages destined for other locations that are not directly accessible to the Modbus Master. Although the Modbus standard has no definition for this function, MAXIO I/O modules use a simple form of block address translation to support Store & Forward operation within the Modbus specification framework.

The following “rules” are used for Store and Forward operation:

- The network addresses to be translated and forwarded must be in a single contiguous block of addresses.

MAXIO UIO Module

- The translated addresses must be unique and NOT include the local RTUs address.
- The Master must be capable of ignoring the messages generated with translated addresses (ICL controllers do this automatically). Some Modbus Masters may not like seeing what appears to be a response message with a different address. Since the repeater is by definition “in radio range”, the Master is certain to “see” these messages.

MAXIO I/O modules have three holding registers that control the Store and Forward address translation functions; an “Incoming Base Address” register, an “Outgoing Base Address” register, and a “Block Size” register.

When a message is received by a MAXIO I/O module, it first checks to see if the message is intended for itself. If not, it then checks to see if the message falls within the Incoming range of addresses (Incoming Base through Incoming Base + Block Size - 1) or within the Outgoing range of addresses (Outgoing Base through Outgoing Base + Block Size - 1).

If a message falls within the Incoming Range, then the module knows that the message came from the Master (or a previous repeater enroute from the Master) and it translates the address to the Outgoing Range, calculates a new message CRC check block, and retransmits the modified message. Likewise, if a message falls within the Outgoing Range, then the module knows that the message came from a downstream module (or a previous repeater) and it translates the address to the Incoming Range, calculates a new message CRC check block, and retransmits the modified message back towards the Master.

There is no limit to the number of repeater hops that can be used other than the total number of available addresses (254).

The Store and Forward parameters are set in their own configuration window in the ScadaFlex I/O Toolbox program. In the example shown, addresses from 100 to 109 (block size of 10) will be translated to addresses of 200 to 209. Note that setting any of the three parameters to 0 disables Store and Forward operation.



Power

MAXIO UIO Modules can operate from either AC or DC power. They are typically powered from a 12, 15 or 24 volt DC power supply, or a 12 or 24 volt AC transformer, although they are rated to operate over an even wider range of 10 to 36Vdc or 10 to 26Vac. The incoming voltage level can be read by the Host system.

AC/DC Power Wiring

A MAXIO UIO Module can be powered directly from a transformer or a DC power supply. A transformer is typically the lowest cost installation. If a DC power supply is used, it does not need to be regulated as long as its output doesn't drop below 10Vdc or rise above 36Vdc under all line voltage and load conditions.

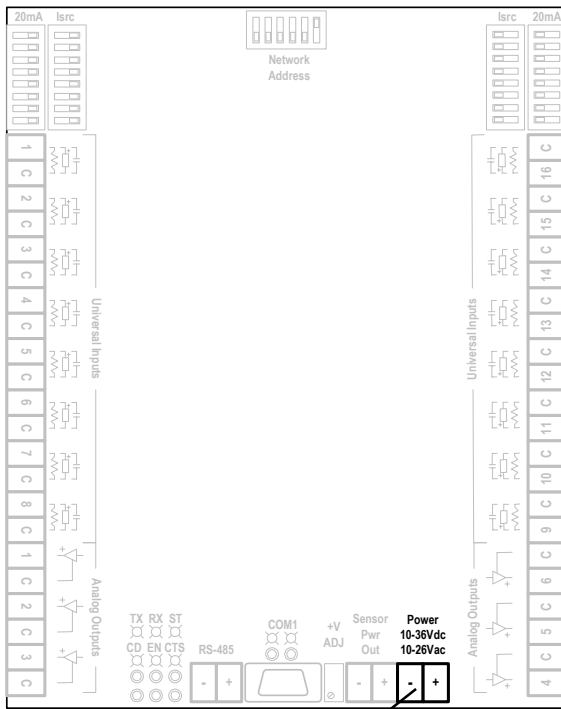

Power Input Terminal Block

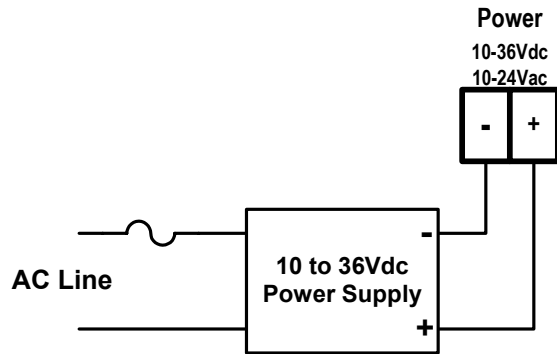

MAXIO DC Power Wiring

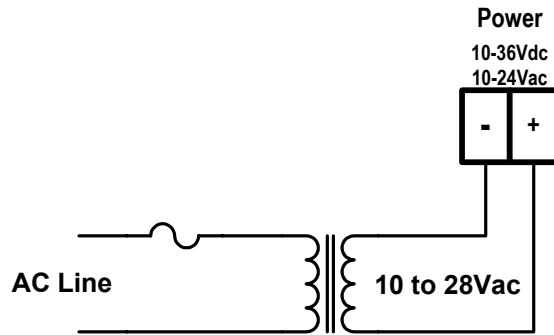

MAXIO AC Power Wiring

Maintenance

MAXIO I/O modules are designed for long-term maintenance-free operation. The only maintenance item for MAXIO UIO modules is a recommended annual calibration check and possible firmware updates as enhancements are made to the product family.

ScadaFlex I/O Toolbox

In addition to some of the specific functions mentioned throughout this manual, the ScadaFlex I/O Toolbox is a convenient Windows software tool for exercising all of the inputs, outputs and functions of the MAXIO UIO module, as well as for performing module calibration. A separate manual that describes the complete operation of the toolbox program is available, entitled “ScadaFlex I/O Toolbox - Technical Reference Manual” (part# 60292xxx where xxx is the revision level).

Firmware Updates

The MAXIO I/O module microprocessor firmware is easily and quickly updated using the “Load I/O Firmware” function (under the File menu) in the ScadaFlex I/O Toolbox, or by using a stand-alone Windows Bootloader utility program.

With either program, the update procedure is the same:

- 1) Connect a serial port from your PC or laptop computer to the RS-232 port of the MAXIO I/O module using a null module cable (a null modem cable is supplied with the I/O Toolbox software).
- 2) Select a path to where the new firmware was saved on your computer
- 3) Select “Start” to start the download.
- 4) Cycle power (turn off power, wait a few seconds, and turn power on) to the MAXIO I/O module when prompted
- 5) A progress bar will be displayed as the firmware is updated. The update process takes less than a minute.
- 6) The new update can be verified by checking the firmware revision level under the Help menu (About . . .) in the ScadaFlex I/O Toolbox. It should match the revision level documented in the new firmware release notes.

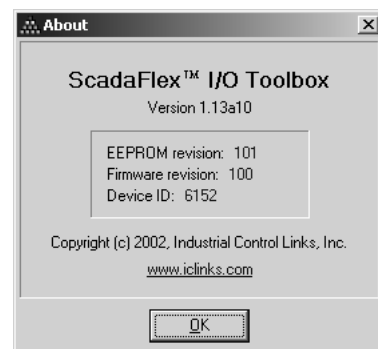

Calibration

MAXIO UIO modules contain precision analog circuits. To ensure that the module is operating at its full specifications, it is recommended that calibration be verified annually.

All calibration is performed via Modbus registers. There are no calibration trimpots. Although the calibration registers can be accessed by any Modbus Master device or program, the easiest way to perform calibration on the UIO module is to use the ScadaFlex I/O Module Toolbox software.

Preparation

- 1) Apply power to the UIO module and allow it to stabilize for at least 10 minutes before making calibration checks or adjustments.
- 2) Attach a null-modem serial cable (supplied with the ScadaFlex Toolbox software) between your PC computer and the UIO module.
- 3) The Toolbox software must be configured to talk to the UIO module by settings found under the “Setup” menu in “Local Communications”.

For the Toolbox software to communicate with the MAXIO UIO module, you must specify the COM port on your PC that you have connected to the module, and the software must have the correct baud rate and network address settings.

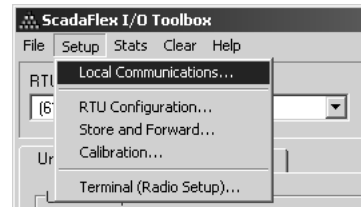

Address

In most cases, the address of the module is set directly by the DIP switches at the top of the module. Remember though that the module has a register that can be set to a nonzero value that offsets the address DIP switches, so the module addressing may not be obvious from the DIP switch settings. This is unlikely unless the module is part of a very large I/O system. If you are in a NON-NETWORKED environment (i.e. your PC connected to only one module) and you are not sure of the module address, an address of 255 can be used. This is a general purpose address that any MAXIO module will respond to regardless of DIP switch and address settings.

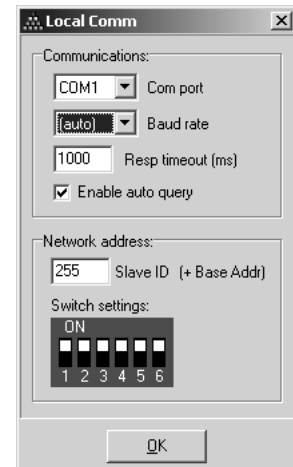

Baud Rate

Select the baud rate setting to match the configuration of the MAXIO module. If you do not know the modules setting, select “auto” and the Toolbox software will attempt to figure out what the module is set to.

If you are properly connected and configured, the Toolbox software will automatically identify the MAXIO UIO module and display a window similar to the one shown below.

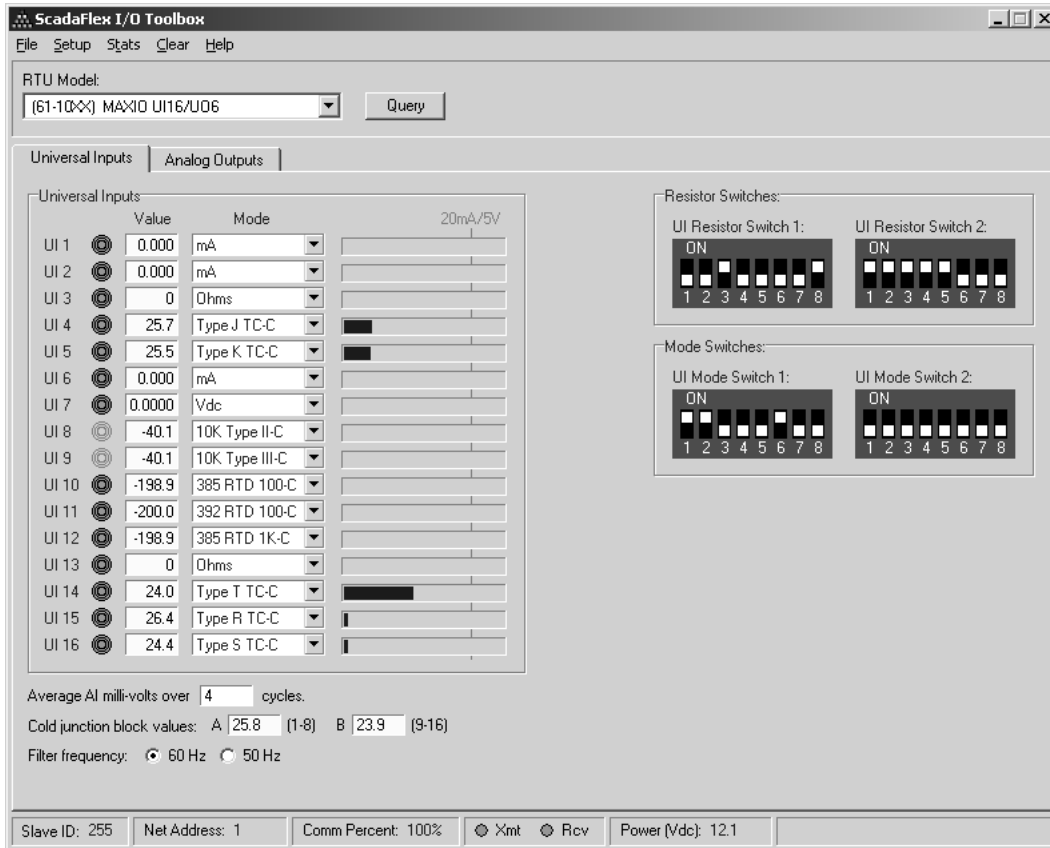

At the bottom of the window, you should see “Comm Percent 100%” and both the Xmit and Rcv indicators on solid GREEN. Note the Slave ID and Net Address values. The “Slave ID” is the address setting that you set in the Toolbox configuration. The “Net Address” is the actual address configuration of the MAXIO UIO module.

The remainder of the screen shows the current configuration and readings for the Universal Inputs, as well as the configuration DIP switch settings that should be used based on the configuration values.

To get into the calibration windows, select “Calibration” under the “Setup” menu.

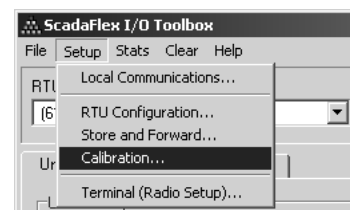

AI Current Calibration

When you select “Calibration”, the top window displayed is the (20mA) current calibration window. Other calibrations windows are selected by clicking on the tabs along the top of the frame.

Before applying a current calibration signal, be sure that the current mode switches are all turned ON and the “Isrc” switches are all turned OFF. These switches are located near the top of the UIO module, on either side.

To calibrate the inputs, apply a precision 20.000mA signal to each input and adjust the corresponding “Numerator” value for the correct reading. Each input has its own calibration value. The numerator that you are setting is the value that is multiplied times the A/D reading, then the result is divided by 65535 to provide a calibrated reading of 0 to 20,000 for inputs of 0 to 20mA. The numerator values should all be in the 41,000s as shown.

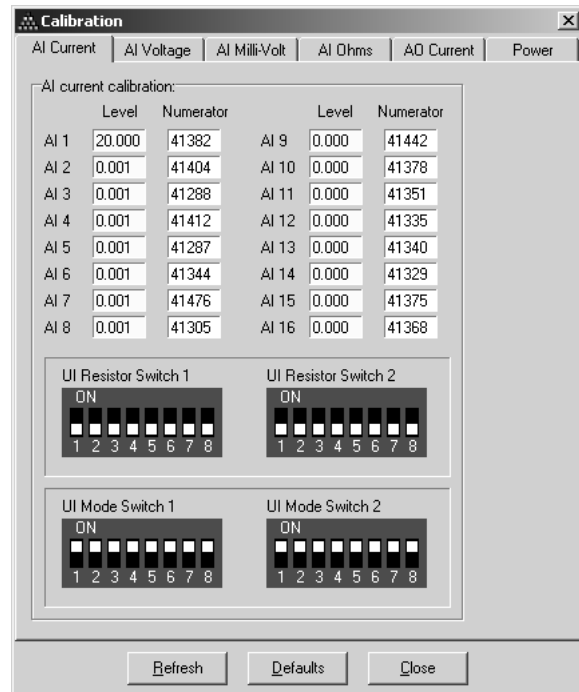

AI Voltage Calibration

For voltage (5Vdc) calibration, click on the “AI Voltage” tab.

Before applying a calibration signal, be sure that the current mode switches and the “Isrc” switches are all turned OFF.

Apply a precision 5.0000Vdc signal to inputs 1 and 9 and adjust the “Numerator” values for the correct readings. The numerator values should be very close to 50,000 as shown.

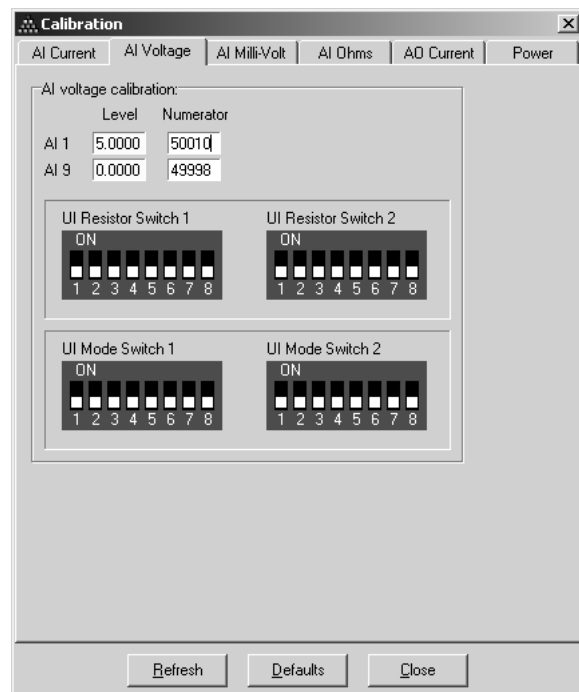

AI Millivolt Calibration

For millivolt (300mV) calibration, click on the “AI Milli-Volt” tab.

Before applying a calibration signal, be sure that the current mode switches and the “Isrc” switches are all turned OFF.



For best results, set millivolt averaging to “4” or “8” in the Universal Inputs window.

Millivolt calibration has a numerator and an offset value for both of the calibration channels.

To set the offset value, short inputs 1 and 9 to their adjacent ground terminals. Adjust the offset value for a reading of 0.00mV. The offset should be in the range of +/- 10.

Apply a precision 5.0000Vdc signal to inputs 1 and 9 and adjust the “Numerator” values for the correct readings. The numerator values should all be in the 64,000s.

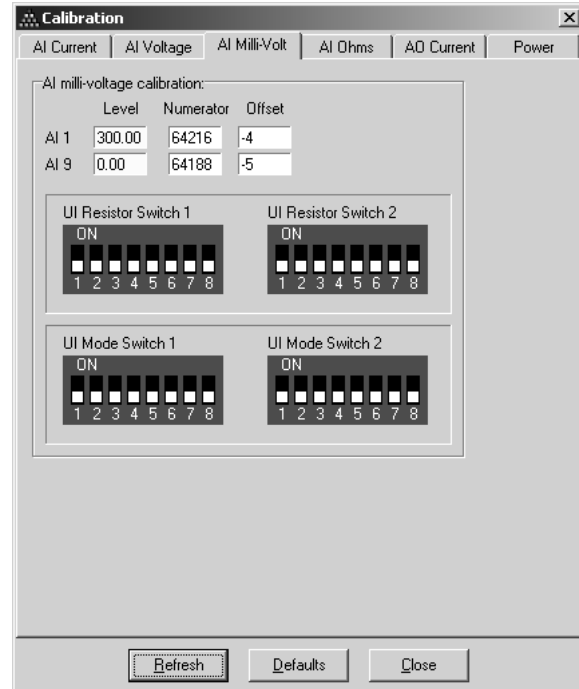

AI Ohms Calibration

For ohms (resistance) calibration, click on the “AI ohms” tab.

To prepare for ohms calibration, be sure that the current mode switches are all turned OFF and the “Isrc” switches are all turned ON.

To calibrate each input, connect a known precision resistor value (0.1% or better), between 10,000 and 20,000 ohms, to each input. Adjust the “Numerator” values for the correct readings (open inputs read 65,535). Each input has its own calibration value. The numerator values should all be very close to 20,000 as shown.

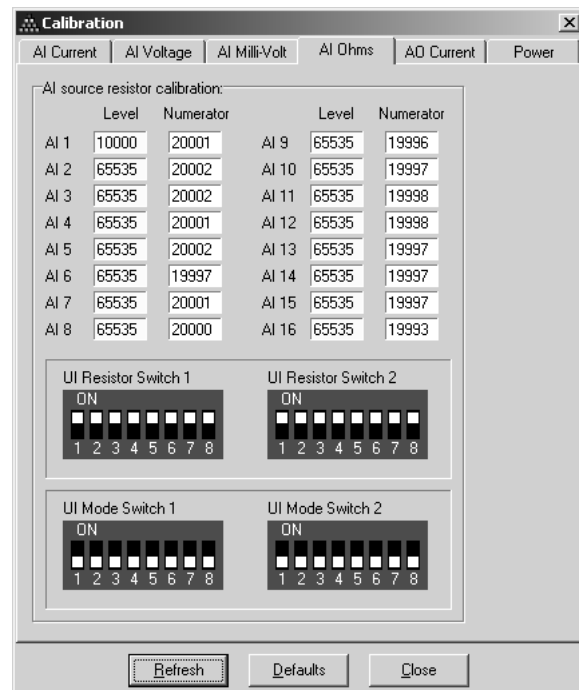

AO Current Calibration

For calibration of the Analog Outputs, click on the “AO Current” tab.

Calibration of the Analog Outputs requires a precision digital current meter to be connected the analog outputs and adjusting the calibration values for the correct readings on the meter.

To calibrate an output, first enter a “Level” of 1mA and adjust the Offset value so that the meter reads 1.0000mA to within 1 LSB (+/- 0.004883mA). The offset value should be in the range of +/- 10.

Set the “Level” to 20mA and adjust the Numerator value so that the meter reads 20.0000mA to within 1 LSB (+/- 0.004883mA). The numerator values should all be close to 13,000.

Set the “Level” back to 1mA and verify that the output is still within 1 LSB (1.000mA +/- 0.004883mA). If a change is required, go back and check the output at 20mA again.

Repeat until no adjustments are required to achieve +/- 1LSB at both 1mA and 20mA.

Power Calibration

For calibration of the power input and sensor power output readings, click on the “Power” tab.

Measure the voltage at the power input terminals and sensor power output terminals and adjust the numerator values for the correct readings.

The numerator values should all be close to 4000 (+/-200) as shown.

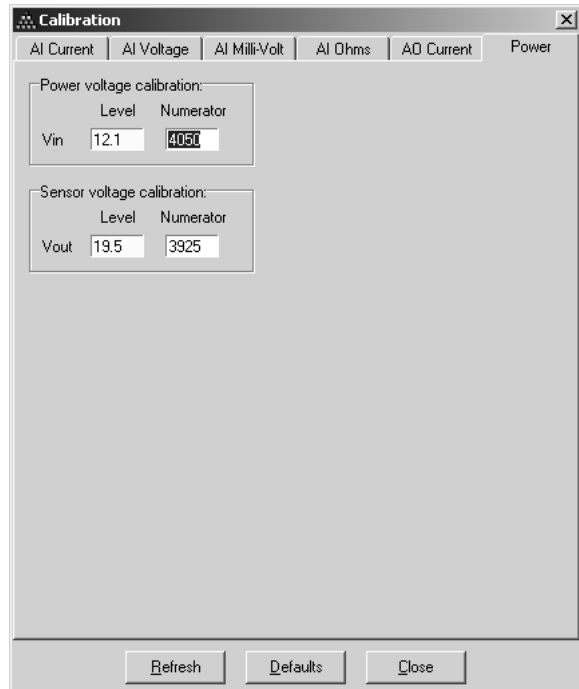
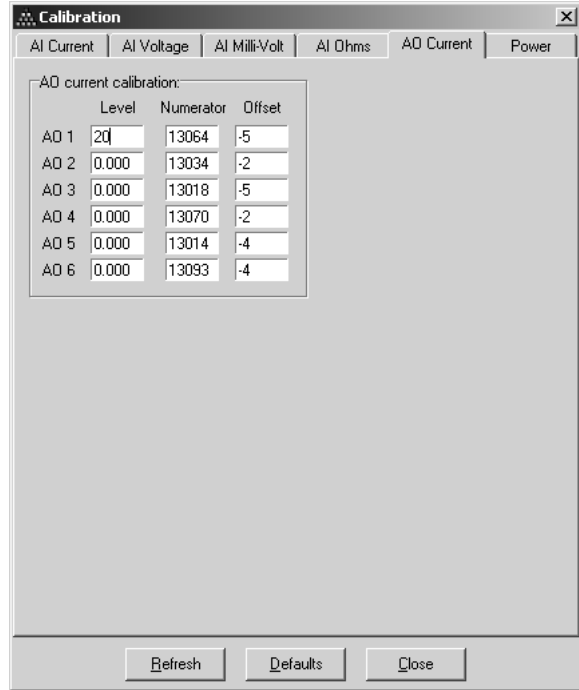

Internal Spread Spectrum Radio Option

MAXIO I/O modules are available with internal Spread Spectrum Radios, requiring no license and communicating at rates of up to 115K baud.

The spread spectrum radios used in MAXIO I/O modules may be ordered for operation in either one of two bands designated by the Federal Communications Commission (FCC); 900 MHz (902 to 928MHz) and 2.4GHz ((2.400 to 2.4835MHz). Unlike conventional radio systems that transmit and receive on fixed frequencies, spread spectrum radios “hop” periodically from one frequency to another in a pseudo random pattern. The hopping pattern is user settable, and all radios that are configured to talk to each other follow this pattern, changing frequencies up to 100 times per second. The radios can utilize a total of 112 different frequencies.

Spread spectrum radios tend to be less affected by outside interference and are more secure than conventional radios because they are constantly changing operating frequency. If a spread spectrum radio encounters interference at a particular frequency, it simply picks up where it left off after hopping to the next frequency a few milliseconds later. The radios offer very high data reliability, utilizing a unique 32-bit error detection and correction scheme to ensure that corrupted data is never passed to the Controller. This protection is above and beyond the protocol level error handling.

The radios embedded in MAXIO I/O modules can deliver up to one watt of RF power, the maximum allowed by law in these frequency bands. This is a lower power than other types of radios operating at fixed licensed frequencies. These spread spectrum radios can have a range of up to 60 miles. The radios have a built-in repeater function, so that each radio can serve as a repeater to relay the messages of other radios located farther out as well as communicating the data from the Controller. There is no limit, other than transmission time, to the number of repeater hops used, so spread spectrum radio networks can provide hundreds of miles of coverage.

The radios in MAXIO I/O modules support real-time on-line diagnostics. The radios can be remotely configured and can even have the microprocessor firmware updated from a Master station. The remote diagnostics capability provides immediate status information for any segment of the radio network, including repeater links. This data can include Average signal strength and noise levels, as well as specific signal and noise levels for each of the 112 hopping frequencies. Additional information such as antenna reflections (SWR), operating temperature, and data error rates are available to analyze the performance of each portion of the radio network.

Radio Installation

The internal MAXIO I/O module spread spectrum radio is manufactured by Freewave Technologies (www.freewave.com) and is functionally similar to their stand-alone FGR series radios without requiring any additional panel space, cabling or integration effort. Freewave DGR and FGR series radios may be used together with the MAXIO I/O module radio options.

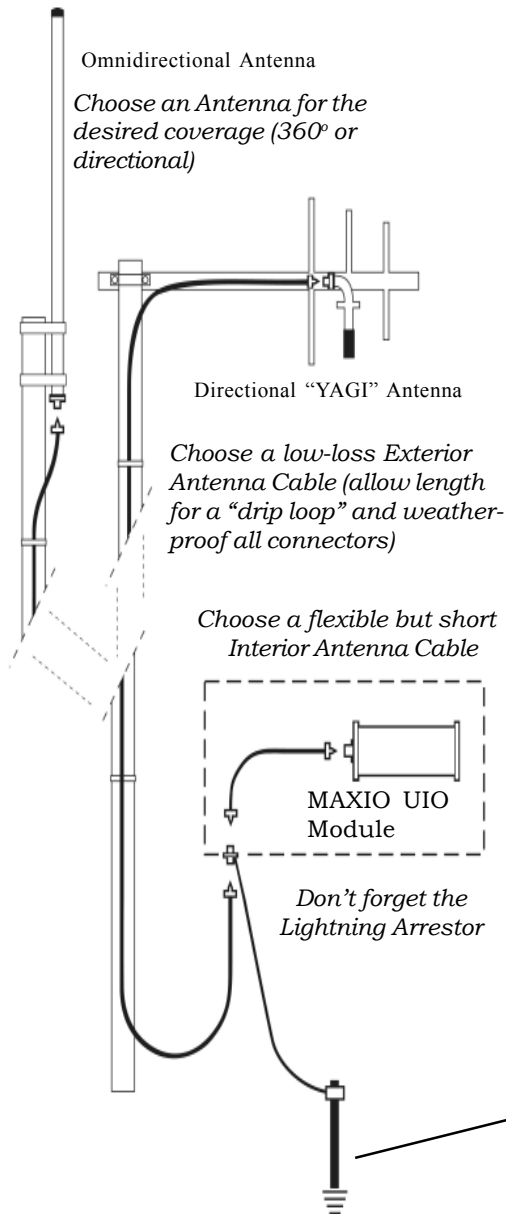

The MAXIO I/O modules radio option uses a female “SMA” type antenna connector. The antenna connector and the radio status lights are located on upper side of the Controller (see below).

Typically, a short, lightweight cable (such as RG-223 or LMR-200) connects between the radio antenna connector and a lightning arrester in the panel. A lightning arrester with dedicated ground rod is required for any outdoor installation. The lightning arrester can also serve as a bulkhead connector to pass through the cabinet wall and transition to heavier, lower-loss type exterior antenna cables such as LMR-400 and LMR-600. These cables then connect to Yagi (directional) or Omni (omni-directional) antennas. LMR-600 cable has lower loss for longer runs. LMR-400 is cheaper and more flexible, but less than 100ft. of cable can cut the signal strength in half! Helix has the lowest loss, but is stiff and hard to work with.

Once the radio system has been verified, all exterior connections should be taped and weatherproofed for long-term reliability.

Ground the lightning arrester with a dedicated ground rod and a SHORT heavy (#8 or better) ground cable. Do not use conduit or water pipes for this ground connection.

SMA Antenna Connector on side of MAXIO UIO Module



Radio Configuration

The spread spectrum radio option is automatically connected to the second serial port internal to the module. The port configuration is identical to the configuration of the primary RS-232/RS-485 port. Like any other serial link, the radios operating parameters must be set to match those of the attached serial port in the I/O module. While the serial port parameters are set using The ScadaFlex I/O Toolbox software on a PC, the radio is configured using a PC computer connected to the radio diagnostic serial port close to the antenna connector. Use a “straight through” serial cable. Communicating with the radio requires a terminal emulation program. This can be either the terminal emulator built into the I/O Toolbox software, or the HyperTerminal software that comes with Windows, or similar alternative software. Set the terminal emulation configuration to:

19,200 baud, no parity, 8 data bits and NO flow control

The configuration menus in the radio are accessed by typing “Shift U” (be sure that “Caps Lock” is OFF, then while holding down the Shift key, press the U key). You should see the menu pictured below and the three internal radio status lights near the COM1 connector should be GREEN. Pressing the Escape key several times will cause the radio to return to normal operation.

Radio Configuration - MAIN MENU

When the radio has been placed into configuration mode, the radio status lights will glow green and the Main Menu screen will be displayed:

```

                                MAIN MENU
                                Version 2.23 11-21-2002
                                Standard Hop Table
                                Modem Serial Number 911-8743

(0)   Set Operation Mode
(1)   Set Baud Rate
(2)   Edit Call Book
(3)   Edit Radio Transmission Characteristics
(4)   Show Radio Statistics
(5)   Edit MultiPoint Parameters
(6)   TDMA Menu
(8)   Chg Password
(Esc) Exit Setup

Enter Choice

```

From this menu, a series of sub-menus are accessed to examine or set operating parameters. The radios are highly configurable, but for most applications, only menus 0 (Set Operation Mode), 1 (Set Baud Rate), 3 (Edit Radio Transmission Characteristics), 5 (Radio Statistics) and 5 (Edit MultiPoint Parameters) are applicable and discussed in the remainder of this section. A full operations manual for the radios is available.

Radio Configuration - SET OPERATION MODE

The “Set Operation Mode” screen is selected by pressing “0” at the Main Menu. In this screen, the radios basic operating mode is chosen. The screen is depicted below:

```

                                SET MODEM MODE
                                Modem Mode is      2

(0) Point to Point Master
(1) Point to Point Slave
(2) Point to MultiPoint Master
(3) Point to MultiPoint Slave
(4) Point to Point Slave/Repeater
(5) Point to Point Repeater
(6) Point to Point Slave/Master Switchable
(7) Point to MultiPoint Repeater
(F) Ethernet Options
(Esc)      Exit to Main Menu

Enter Choice
```

The current operating mode for the radio is always shown at the top of this screen just under the title header.

Of the 9 available operating modes, only three of the modes are typically used with the Ultima Controllers. These three modes are the “Point to Multipoint” operating modes:

Point to Multipoint Master

In this mode, there must be one, and only one Master radio in a system. All of the other radios in the network will operate as slaves to the Master. Typically, the radio in a MAXIO I/O module is a slave, not a Master.

Point to Multipoint Slave

After a single radio has been designated as the Master, the remaining radios in the network must be set as “Slaves” using selection #3 in the menu.

Point to Multipoint Slave/Repeater

To reach outlying areas in the network, the Slave radios can act as repeaters. Slave radios that will also act as repeaters are configured using selection #7 (Point to MultiPoint Repeater) in the menu. Be sure to also enable Slave/Repeater operation in Menu #5.

Return to the Main Menu

Once a radios mode has been set, press the ESC (escape key) to get back to the Main Menu (only press once, or else you will end up back at the “C>” prompt).

Radio Configuration - SET BAUD RATE

The “Set Baud Rate” screen is selected by pressing “1” at the Main Menu. In this screen, the radios basic serial communication parameters are chosen. The screen is depicted below:

```

                                SET BAUD RATE
                                Modem Baud is 115200

(0)  230,400
(1)  115,200
(2)  76,800
(3)  57,600
(4)  38,400
(5)  19,200
(6)  9,600
(7)  4,800
(8)  2,400
(9)  1,200
(A)  Data, Parity      0
(B)  Modbus RTU       1
(C)  RS232/485        0
(D)  Setup Port       3
(E)  Turn Off Delay   0      Turn On Delay      0
(F)  Flow Control     0
(Esc) Exit to Main Menu
Enter Choice

```

The current communications speed (baud rate) setting for the radio is always shown at the top of this screen, just under the title header. The baud rate can be set to any one of ten standard speeds by simply typing a 0 through 9 corresponding to baud rates of 1,200 baud to 230,400. Any of these speeds may be used with the EtherLogic Ultima controller. The speed selected MUST match the port speed selected using the ScadaFlex I/O Toolbox software.

Parity

The radio supports the standard “Odd, Even or None” parity selections. For most applications including those using Modbus, 0 or “None” should be used.

Modbus RTU

This parameter should normally be set to “1” (enabled), forcing the radio to keep the integrity of a single message as one packet instead of using multiple packets which does not meet Modbus standard timing requirements.

RS-232/485, Turn Off Delay, Turn On Delay and Flow Control

These are not used in the and must be set to “0”.

Setup Port

Set this parameter to 3. This enables both radio ports for configuration.

Radio Configuration - EDIT RADIO TRANSMISSION CHARACTERISTICS

The “Edit Radio Transmission Characteristics” screen is selected by pressing “3” at the Main Menu. The screen, with typical settings for a SCADA system, is depicted below:

```

                                RADIO PARAMETERS

WARNING: Do not change parameters without reading manual

(0)      FreqKey                5
(1)      Max Packet Size        8
(2)      Min Packet Size        9
(3)      Xmit Rate               1
(4)      RF Data Rate           3
(5)      RF Xmit Power          10
(6)      Slave Security          0
(7)      RTS to CTS              0
(8)      Retry Time Out         255
(9)      Low power Mode          0
(A)      High Noise              0
(B)      MCU Speed               0
(C)      Remote LED              1
(Esc)    Exit to Main Menu

Enter Choice
```

The parameters in this menu are geared towards handling special circumstances and should normally be left as shipped from the factory. One item though; “Remote LEDs”, must be turned on in order to enable the status LEDs located between the COM1 connector and the address switches. Be sure this parameter is set to a 1.

Most of the other parameters in this screen are used to optimize the radios operation in the event of problems in the field. They improve the operation of the radio in close proximity with other radio networks, in high (radio) noise environments, or to optimize the operation of the radio for certain mixes of data or types of protocols. In general, the radios are plug-and-play and these parameters are best left at the factory settings unless a technical support person recommends changing them.

Typically, your radio setup should match the screen pictured above.

Radio Configuration - SHOW RADIO STATISTICS

The “Show Radio Statistics” screen is selected by pressing “4” at the Main Menu. The screen is depicted below:

MODEM STATISTICS				
Master-Slave Distance (m)	0083200			
Number of Disconnects	0			
Radio Temperature	0			
Antenna Reflected Power	0			
Transmit Current (mA)	0000			
	Local	Remote1	Remote2	Remote3
Average Noise Level	12			
Average Signal Level	0			
Overall Rcv Rate (%)	0			
C086EF				
Press <ret> for Freq Table, <Esc> to return to main menu				

The radio statistics screen shows an accumulated history of information regarding the performance of the radio and the quality of the radio link. Unlike the “real-time” updated information available at the Master, this information is a snapshot that can only be viewed while not operating, but it does provide a local tool to analyze the performance of a radio link.

Master-Slave Distance (m)

This value in meters is valid for distances over 1 Km (0.6 miles)

Radio Temperature

Should be 75 (°C) or less.

Average Noise and Signal Levels

These values are an average across all frequencies. Detailed information by frequency is available by displaying the Frequency Table accessed from this screen (see lower prompt line). Ideally, the noise level should be below “30” and the signal level should be at least “15” more than the noise. Note that this is NOT in dB, but arbitrary units to provide a relative signal strength and noise measurement.

Overall Rcv Rate (%)

This value provides an indication of the quality of the radio link and the impact on data throughput. A good quality link will have an Overall Receive Rate of 75% or better. The radio will not pass erroneous data, but a lower Overall Receive Rate indicates that data throughput might be affected at higher data rates, such as 115,200 baud.

Radio Configuration - EDIT MULTIPOINT PARAMETERS

The “Editing MultiPoint Parameters” screen is selected by pressing “5” at the Main Menu. The screen, with typical settings for the EtherLogic LC, is depicted below:

MULTIPOINT PARAMETERS		
(0)	Number Repeaters	1
(1)	Master Packet Repeat	3
(2)	Max Slave Retry	9
(3)	Retry Odds	9
(4)	DTR Connect	0
(5)	Repeater Frequency	0
(6)	Network ID	30
(7)	Reserved	
(8)	MultiMaster Sync	0
(9)	1 PPS Enable/Delay	255
(A)	Slave/Repeater	0
(B)	Diagnostics	0
(C)	SubNet ID	Disabled
(D)	Radio ID	Not Set
(Esc)	Exit to Main Menu	
Enter Choice		

Number of Repeaters

Repeaters extend the range of a radio network at the expense of speed. Any radio can also serve as a repeater. Set this parameter to 1 if you are using ANY repeaters. All radios in the network must have the same setting.

Master Packet Repeat

With a high quality link, set to 0 or 1 for maximum throughput. With a poor quality link, a higher number will improve getting individual messages though at the expense of speed and throughput. For Modbus networks, this value must be set to 3.

Network ID

This parameter helps avoid conflicts with other radio networks. All radios in the network should be set to the same ID value. Other networks must use a different value. Set this to any value below 4095, except the default (255).

Slave/Repeater

Set to 1 if this radio is a repeater as well as a node on the network. Be sure to set the Modem Mode (Menu #2) to *(7) Multipoint Repeater* also.

Diagnostics

Set to 1 for this radio to provide diagnostic data back to the Master.

Specifications

UNIVERSAL INPUTS

Quantity	16
Number of Universal Inputs	16
A/D Converter Resolution	20 bits (1 part in 1,048,560)
Maximum Reading Resolution	16 bits (1 part in 65,536)
Converter Type	Delta-Sigma
Input Resistance	
Voltage & Thermocouple	>1 Million Ohms
Current	121 ohms
Resistance & Contacts	20,000 ohms
Analog Input Signal Range	
Current	20mA (0mA to 46mA)
Voltage	5Vdc (0Vdc to 5.625Vdc)
Millivolts	+/-300mV (-300mV to +300mV)
Resistance	65,000 ohms (0 to 65,535 ohms)
Thermocouples	Type J (-240.7°C to 1199.0°C) Type K (-261.2°C to 1369.5°C) Type T (-263.2°C to 398.8°C) Type E (-267.4°C to 999.0°C) Type R (-43.1°C to 1759.8°C) Type S (-41.3°C to 1759.1°C) Type B (-253.4°C to 1792.1°C) Type N (-255.4°C to 1296.8°C)
Thermistors	10K Ω - II (-401°C to 173.9°C) 10K Ω - III (-401°C to 188.0°C)
RTDs	100 Ω - 385 (-198.9°C to 869.4°C) and 1K Ω - 385 (-198.9°C to 869.4°C) 100 Ω - 392 (-200.0°C to 629.7°C)
Accuracy @ 25°C (% Full Scale)	
Current	+/- 0.01%
Voltage	+/- 0.01%
Millivolts	+/- 0.01%
Resistance	+/- 0.01% (<25K Ω) +/- 0.3% (>25K Ω)
Thermistors & RTDs	+/- 0.1%
Thermocouples	+/- 0.1% + Cold Junction Tolerance
Cold Junction	+/- 1°C
Temperature Coefficient	
Voltage & Thermocouples	+/- 5ppm/°C maximum
Current	+/- 30ppm/°C maximum
Thermistor, RTD & ohms	+/- 30ppm/°C maximum
Input Overload Clamping	Inputs limited to 50mA and 6Vdc
Overload / Transient Protection	Transorb/Self Resetting Polyfuse

ANALOG OUTPUTS

Quantity	6
Output Range	0 or 4 to 20mA (0 to 21mA)
Converter Type	High-frequency PWM
Resolution	12 bits (1 part in 4096)
Maximum Load Resistance	250 Ω @ 10Vdc loop power 500 Ω @ 15Vdc loop power 750 Ω @ 20Vdc loop power 1000 Ω @ 25Vdc loop power
Accuracy @ 20°C (% Full Scale)	+/- 0.1%
Temperature Coefficient	+/- 75ppm/°C maximum
Ripple & Noise	0.01% maximum

COMMUNICATIONS

Serial Ports	2 (1 standard + 1 internal)
Communications Baud Rates	2400 baud to 115,200 baud
Serial Port Interfaces	COM #1 RS-232, 9 pin D Male RS-485, 2-pos. removable terminal block COM #2 Optional Internal Radio or 2nd RS-232/RS-485 port:
Protocols	Modbus RTU (slave) or ICL Bricknet (peer-to-peer), auto-detect

COMMUNICATIONS OPTIONS (one per module)

Internal Spread Spectrum Radios	900MHz, 1W, up to 115Kbaud, 2.4GHz, 0.5W, up to 115Kbaud
Serial Comm. Option	RS-232/RS-485 Add-on Port

GENERAL SPECIFICATIONS

Field I/O Wiring Terminations	Removable Terminal Blocks
Wire Size	#14 to #26 stranded or solid #12 stranded only
Dimensions	7.0" W x 6.0" L x 2.5" D (178mm x 152mm x 64mm)
Power Input	10 to 26Vac, 10 to 36Vdc
no internal radio/extra serial port	0.25W (w/sensor power OFF)
Sensor Power Supply output	7 to 32Vdc, 0.5A maximum
Temperature	-40°C to 75°C (-40°F to 167°F)
Humidity	5 to 95% RH (non-condensing)

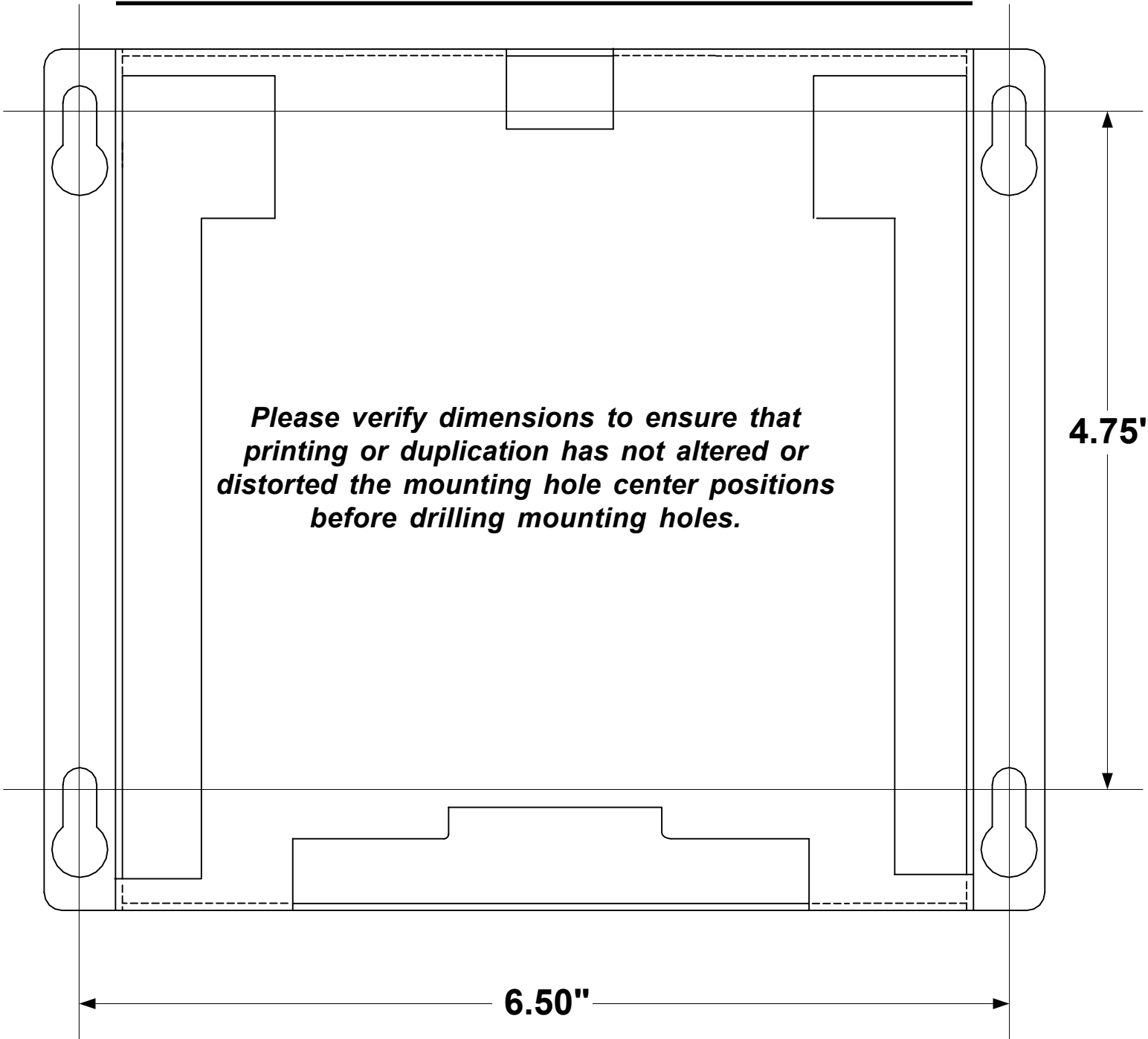

Please verify dimensions to ensure that printing or duplication has not altered or distorted the mounting hole center positions before drilling mounting holes.

6.50"

4.75"

Scale = 1:1
MAXIO UIO Mounting Template

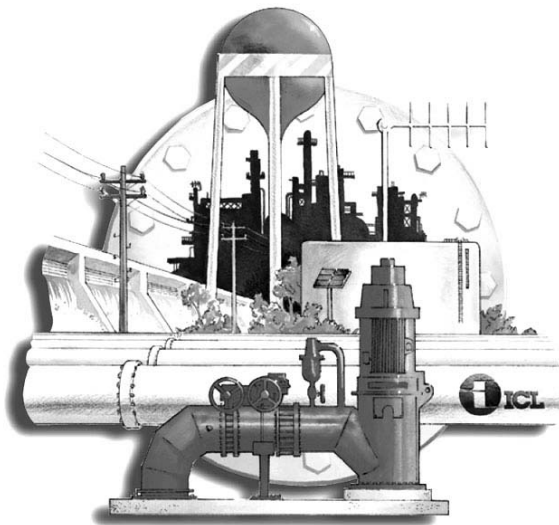

Industrial Control Links, Inc.
12840 Earhart Ave.
Auburn, CA 95602

USA/Canada: (800) 888-1893
International: (530) 888-1800

Fax: (530) 888-1300
(530) 888-7017

E-mail: icl@iclinks.com

Web-site: www.iclinks.com